



ITT

Commercial

Goulds Pumps

AquaBoost™ Model ABS – Variable Speed Constant Pressure Systems



Flow rates up to 53 GPM

FEATURES

The AquaBoost pump controller and complete booster package kits provide an economical answer for municipal water district customers with low water pressure. Both domestic and light commercial applications can benefit. As water use increases, the AquaBoost changes pump speed to keep line pressure constant. Large supply tanks are eliminated and up to 50% of the energy required by a full speed pump is saved.

The AquaBoost is available with a range of flow rates to handle homes with up to four baths, irrigation systems, filtration and fire suppression systems. The AquaBoost is available as either a separate controller or as part of a complete pump package with everything you need to plumb it to a domestic water line.



Goulds Pumps is a brand of ITT
Residential and Commercial Water.

www.goulds.com

Engineered for life

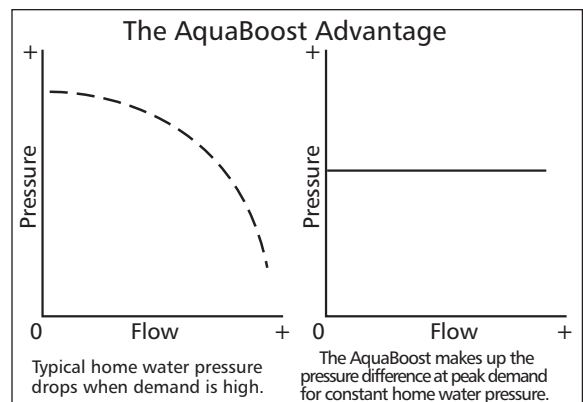

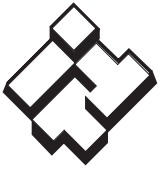

ITT

GOULDS PUMPS Commercial

COMPONENTS

1AB1HM1E2D0 — 4.8 Amp AquaBoost controller, wall mount set, HMS stainless steel pump, transducer, V6P tank, pressure gauge, discharge tee. Controller is pre-wired and pre-programmed. Flows to 20 GPM.

1AB2HM1E2D0 — 4.8 Amp AquaBoost controller, wall mount set, HMS stainless steel pump, transducer, V6P tank, pressure gauge, discharge tee. Controller is pre-wired and pre-programmed. Flows to 37 GPM.

1AB1 — 4.8 Amp AquaBoost controller, wall mount set, transducer, pre-wired, pre-programmed. (Pump and tank not included.)

2AB2HM1F2E0 — 7 Amp AquaBoost controller, wall mount set, HMS stainless steel pump, transducer, V6P

tank, pressure gauge. Controller is pre-wired and pre-programmed. Flows to 37 GPM.

3ABLCB1H2D0 — 10 Amp AquaBoost controller, wall mount set, LCB stainless steel pump, transducer, V6P tank, pressure gauge, discharge tee. Controller is pre-wired and pre-programmed. Flows to 53 GPM.

2AB1 — 7 Amp AquaBoost controller, wall mount set, transducer, pre-wired, pre-programmed. (Pump and tank not included.)

3AB1 — 10 Amp AquaBoost controller, wall mount set, transducer, pre-wired, pre-programmed. (Pump and tank not included.)

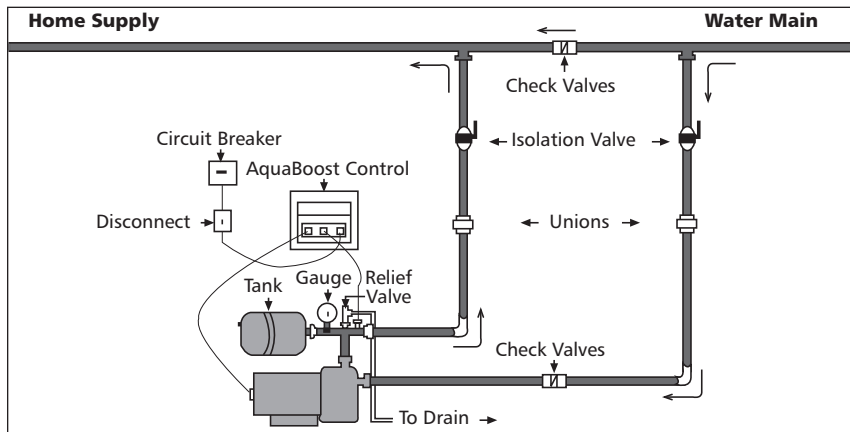

**Typical Municipal
Booster
Water System**

**Typical Well and
Storage Tank
Booster System**

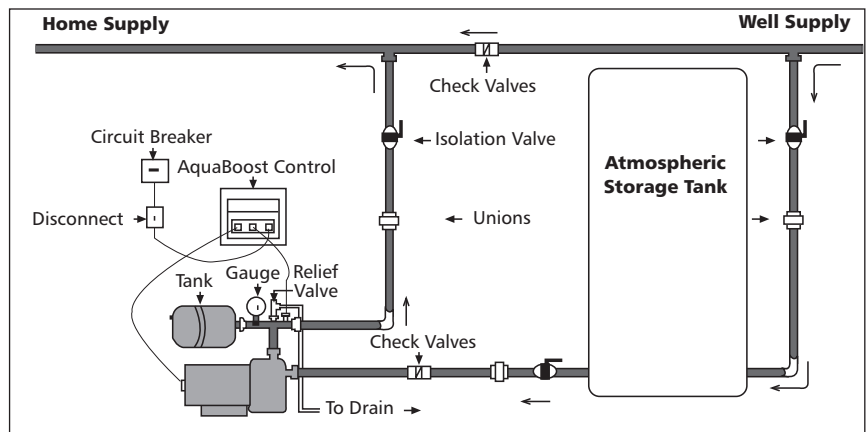

NOTE: Typical installation is on flooded suction or with a positive pressure on the suction. Suction lift is possible with a foot valve assembly. Operation may vary with suction lift.



ITT

GOULDS PUMPS Commercial

AQUABOOST CONTROLLER FEATURES

Input Power — 230V ±15% single phase

Output Power — 230V three phase

Maximum Output Current — 4.8 amps – 1AB1 (1 HP)
— 7.0 amps – 2AB1 (2 HP)
— 10.0 amps – 3AB1 (3 HP)

Input Controls — Up and down buttons to turn unit on and off and set pressure.

Signal Lights — Power on, pump running, inverter stopped, pump stopped, error.

Electrical Efficiency — Over 95%

Protection Against — Short circuit, under voltage, overload, motor temperature, dead heading, run out, suction loss, sensor fault, bound pump, over voltage, radio interference, static discharge. **Note:** Suction loss/run out is set for minimum 10 psi at discharge!

Ambient Temperature — 40° F to 104° F

Maximum Humidity — 90% at 104° F, non-condensing

Air Pollution — Avoid mounting in areas with excessive dust, acids, corrosives and salts.

Controller Enclosure — NEMA 4, IP 55

Approvals — UL, CUL, CE

Mounting — Wall mount with mounting hardware.

Cooling — Fan, continuous.

Transducer — 0.5 - 4.5 VDC with 5 VDC power supply, 150 psi range, 10-foot cable, stainless steel body.

Input Wire — 10 feet of 14 gauge cable. Cable is pre-wired to controller and junction box.

Output Wire — 10 feet of 14 gauge cable. Cable is pre-wired to controller and pump motor (when provided).

PRESSURE RANGE

Nominal Range — Field adjustable from 20 - 80 psi.

⚠ WARNING DO NOT SET REQUIRED PRESSURE ABOVE 80 PSI. SEVERE DAMAGE TO PLUMBING COULD RESULT.

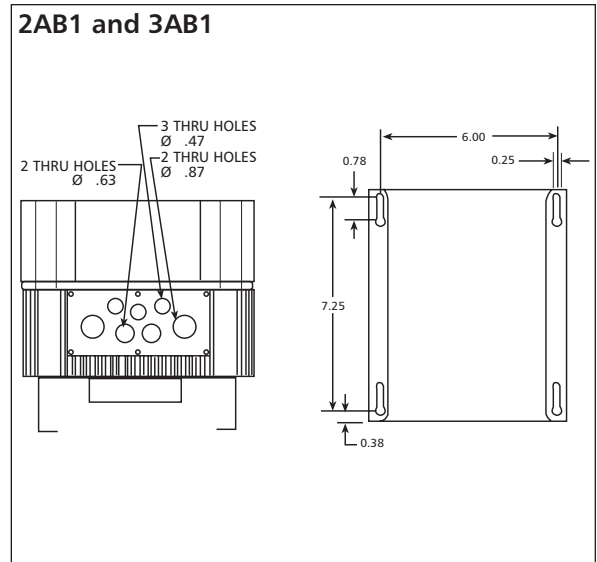
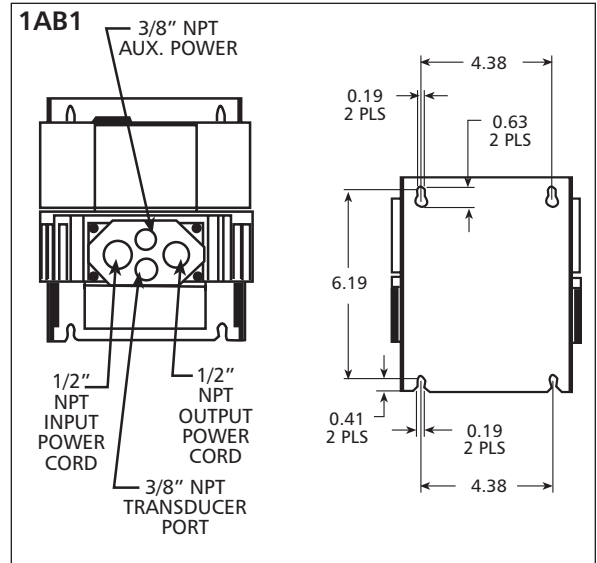

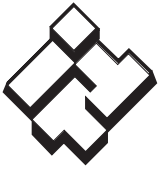

ITT

GOULDS PUMPS
Commercial

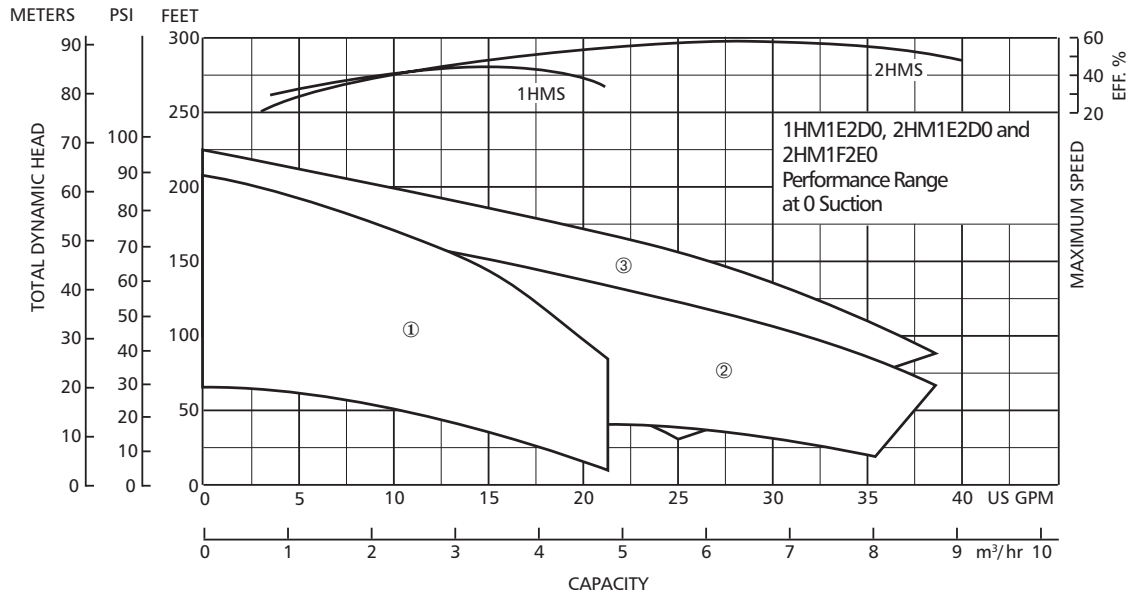

- ① Curve represents pump model 1HM1E2D0, with 1AB1. Flows to 20 GPM.
- ② Curve represents pump model 2HM1E2D0, with 1AB1. Flows to 37 GPM.
- ③ Curve represents pump model 2HM1F2E0, with 2AB1. Flows to 37 GPM.

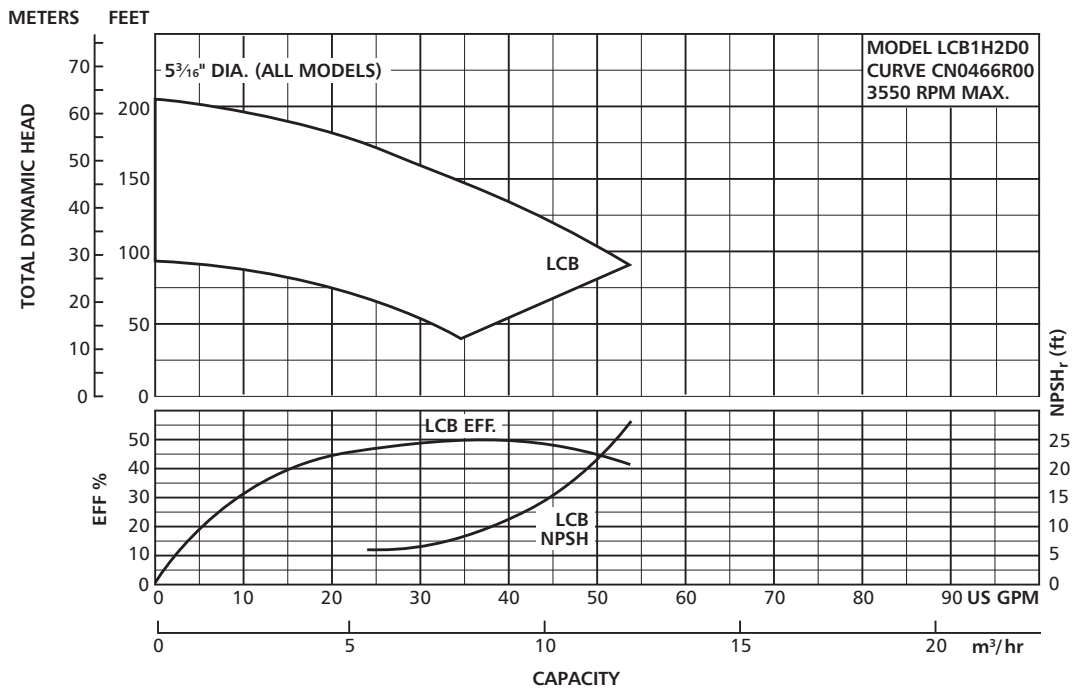

NOTE: LCB pump is used with 3AB1 controller.



ITT

GOULDS PUMPS Commercial

HMS PUMPS (1HM1E2D0, 2HM1E2D0)

- Capacities** — to 20 GPM (1HM)
to 38 GPM (2HM4/2HM5)
- Rotation** — Right hand clockwise, viewed from motor end
- Materials** — 316L stainless steel for all liquid handling components
- Motor** — 1 HP, ODP, Three Phase, 115/230V (1HM/2HM4)
— 1.5 HP, ODP, Three Phase, 115V/230V (2HMS5)

- Pipe Connections** — 1 x 1 1/4" NPT
- Maximum Temperature of Water** — 120° F
- NOTE:** Tank Liquid Temperature Limit is 120° F
Pump Liquid Temperature Limit is 212° F
- Maximum Pressure** — 128 psi
- Seal** — Carbon / Silicon Carbide / EPR
- Weight** — 27.1 lbs.

Overload protection, starters, heaters not required.

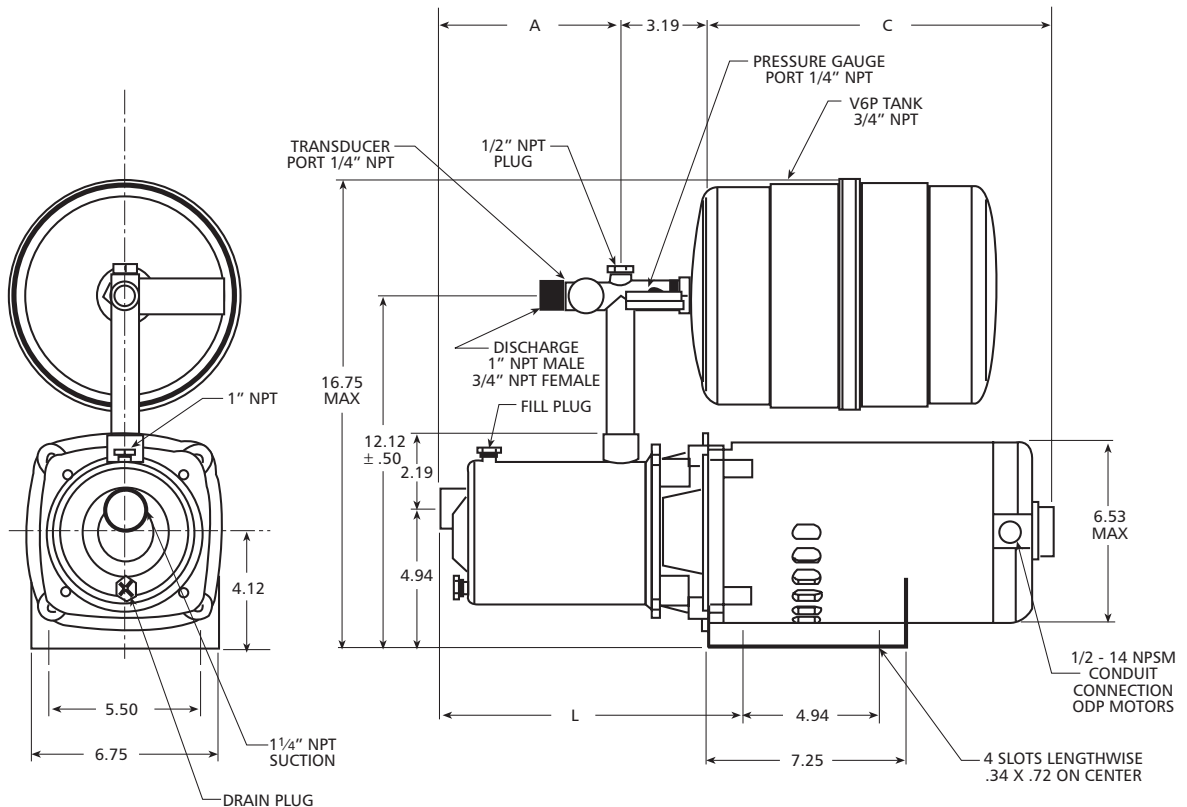

AQUABOOST	A	L	C	MOUNTING
1AB2HM1E2D0	5.75	10.75	11.62	View B
1AB1HM1E2D0	5.75	10.75	11.12	View A
2AB2HM1F2E0	6.73	11.75	11.62	View B

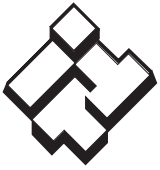

ITT

GOULDS PUMPS Commercial

LC PUMP (LCB1H2D0)

Capacity — to 54 GPM

Rotation — Right hand clockwise, viewed from motor end

Materials — 304 stainless steel for all liquid handling components

Motor — 3 HP, ODP, Three Phase, 115/230V

Overload protection, starters, heaters not required.

Pipe Connections — 1 x 1 1/4" NPT

Maximum Temperature of Water — 120° F

NOTE: Tank Liquid Temperature Limit is 120° F
Pump Liquid Temperature Limit is 212° F

Maximum Pressure — 125 psi

Seal — Carbon / Ceramic / Viton

Weight — 50 lbs.

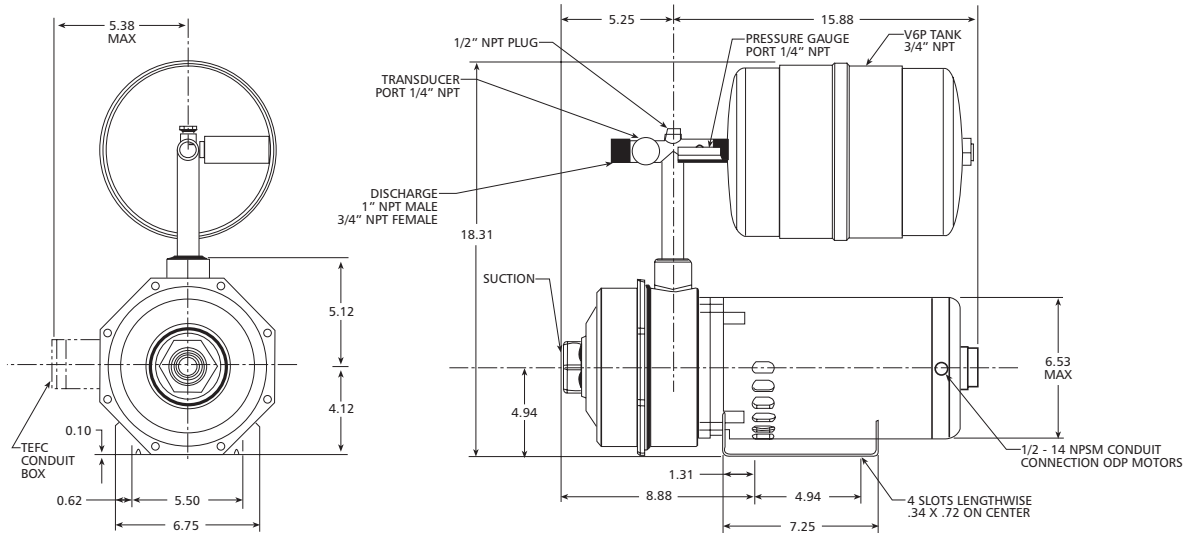



ITT

GOULDS PUMPS
Commercial

ALTERNATE PUMP MODELS FOR USE WITH 1AB1 CONTROLLER

MCC — $\frac{1}{2}$, $\frac{3}{4}$, 1 HP, 3 ph, ODP or TEFC motor versions
3642 — $\frac{1}{3}$, $\frac{1}{2}$, 1 HP, 3 ph, ODP or TEFC motor versions
GT073, GT103 — 3 ph, ODP or TEFC motor versions
HSC07, HSC10 — 3 ph, ODP or TEFC motor versions
HMS — $\frac{1}{2}$ and $\frac{3}{4}$ HP, 3 ph, ODP or TEFC motor versions
5GB, 7GB — $\frac{1}{2}$, $\frac{3}{4}$, 1 HP, 3 ph, ODP or TEFC motor versions
NPE — $\frac{1}{2}$, $\frac{3}{4}$, 1 HP, 3 ph, ODP or TEFC motor versions
NPO — $\frac{1}{2}$, $\frac{3}{4}$, 1 HP, 3 ph, ODP or TEFC motor versions
MCS — $\frac{1}{2}$, $\frac{3}{4}$, 1 HP, 3 ph, ODP or TEFC motor versions
ICS — $\frac{1}{2}$, $\frac{3}{4}$, 1 HP, 3 ph, ODP or TEFC motor versions
LB — All three phase models

Note: These pumps are not currently offered as a packaged kit, from Goulds Pumps.

Submersible Pumps — Additional, external load filters and programming required. Consult factory.

ALTERNATE PUMP MODELS FOR USE WITH 2AB1 CONTROLLER

MCC — $1\frac{1}{2}$ HP, 3 ph, ODP or TEFC motor versions
3642 — $1\frac{1}{2}$, 2 HP, 3 ph, ODP or TEFC motor versions
GT — $1\frac{1}{2}$, 2 HP, 3 ph, ODP or TEFC motor versions
HSC — $1\frac{1}{2}$, 2 HP, 3 ph, ODP or TEFC motor versions
HMS — $1\frac{1}{2}$ HP, 3 ph, ODP or TEFC motor versions
10GB — $1\frac{1}{2}$, 2 HP, 3 ph, ODP or TEFC motor versions
NPE — $1\frac{1}{2}$, 2 HP, 3 ph, ODP or TEFC motor versions
NPO — $1\frac{1}{2}$, 2 HP, 3 ph, ODP or TEFC motor versions
MCS — $1\frac{1}{2}$, 2 HP, 3 ph, ODP or TEFC motor versions
ICS — $1\frac{1}{2}$, 2 HP, 3 ph, ODP or TEFC motor versions

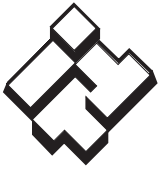

ITT

Commercial

ALTERNATE PUMP MODELS FOR USE WITH 3AB1 CONTROLLER

MCC — 2, 3 HP, 3 ph, ODP or TEFC motor versions

3642 — 3 HP, 3 ph, ODP or TEFC motor versions

GT — 3 HP, 3 ph, ODP or TEFC motor versions

HSC — 3 HP, 3 ph, ODP or TEFC motor versions

18GB — 3 HP, 3 ph, ODP or TEFC motor versions

NPE — 3 HP, 3 ph, ODP or TEFC motor versions

NPO — 3 HP, 3 ph, ODP or TEFC motor versions

MCS — 3 HP, 3 ph, ODP or TEFC motor versions

ICS — 3 HP, 3 ph, ODP or TEFC motor versions

LCB — 3 HP, 3 ph, ODP or TEFC motor versions

AQUABOOST RETRO-FIT KIT

Part Number — 15K40

Includes: V6P Hydro Pro Tank, AG5 pressure gauge, 1" tank tee, 1/2" pipe plugs.



Goulds Pumps, AquaBoost and the ITT Engineered Blocks Symbol are registered trademarks and tradenames of ITT Corporation.

SPECIFICATIONS ARE SUBJECT TO CHANGE WITHOUT NOTICE.

BAQUABOO October, 2006

© 2006 ITT Corporation

Engineered for life