

---

# AquaBoost™ Controller



**Variable Speed  
Pump Control**

**Installation Programming & Operation**

**Models Covered:**

**1AB1 – 4.8A – Single Phase**



**2AB1 – 7.0A**

**3AB1 – 10.0A**

**Software – CP-V00:001**

# INDEX

## Index

System Design .....	1
 Important Safety Instructions .....	2
 Installation Procedures .....	3
1) Pump / AquaBoost Installation .....	3
2) Installation Configuration .....	4
3) Electrical Connections .....	4
4) Pump Priming .....	5
5) Run Test .....	5
 Operator Displays .....	6
• Error Signals .....	6
Appendix A – Pressure Transducer Data .....	7
Appendix B – AquaBoost Controller Drive Head Technical Data .....	8
Limited Warranty .....	12

# System Design

## System Design

### Note

Systems MUST be designed by qualified technicians only and meet all applicable state and local code requirements.

The following diagrams show a typical system using the AquaBoost Controller. Connection can be made directly to a water supply or water can be drawn from a supply tank. Diagram #1 shows a typical set up for a supply tank.

Diagram 1  
System Layout for  
Supply Tank

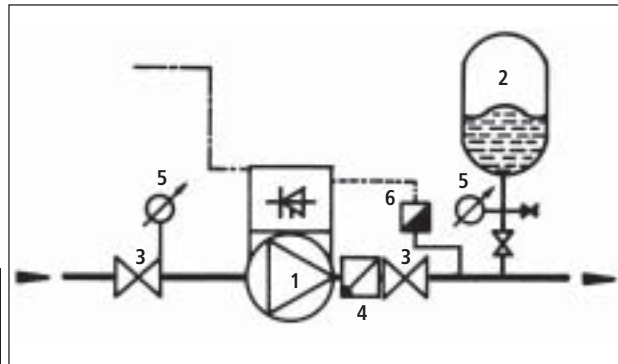

- 1 Pump with AquaBoost Controller
- 2 Diaphragm tank
- 3 Gate valves
- 4 Check valves
- 5 Pressure gauges
- 6 Pressure transducer

Diagram #2 shows a set-up for municipal water connection. This allows pump maintenance without main line shut-off.

Diagram 2  
System Layout  
for Municipal Hook-Up

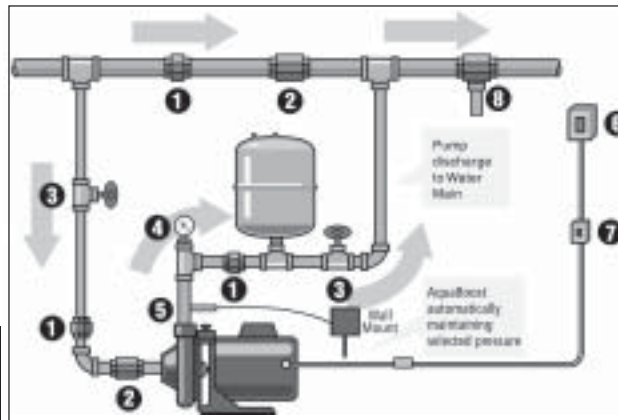

- 1 Union
- 2 Check valve
- 3 Gate valve
- 4 Pressure gauge
- 5 Pressure transducer
- 6 Main power box
- 7 Fuse box or switch
- 8 Pressure relief valve

A diaphragm pressure tank is used on the discharge side of the pump to maintain pressure in the line when there is no demand. This will keep the pump from continuing to run. With the AquaBoost Controller, it is not necessary to have a large tank for supply purposes. In selecting a tank, make sure it can withstand system pressure. The tank should have a capacity of about 10% of the maximum pump flow rate in gpm. Typically, pumps used with the AquaBoost controller use a V6P or larger Goulds Pumps Hydro-Pro® Tank. Pre-charge the tank to the following:

PSI Set Pressure	15	30	45	60	75
PSI Tank Pre-charge	12	21	37	52	64

# ! Safety Instructions



## Important: Read all safety information prior to installation of the AquaBoost Controller.

### Note



This is a **SAFETY ALERT SYMBOL**. When you see this symbol on the pump or in the manual, look for one of the following signal words and be alert to the potential for personal injury or property damage.



**DANGER**

Warns of hazards that **WILL** cause serious personal injury, death, or major property damage.



**WARNING**

Warns of hazards that **CAN** cause serious personal injury, death, or major property damage.



**CAUTION**

Warns of hazards that **CAN** cause personal injury or property damage.

**NOTICE**

Indicates special instructions which are very important and must be followed.

1. This manual is intended to assist in the installation, operation, and repair of the AquaBoost Controller and must be kept with the AquaBoost Controller.

### Note

All operating instructions must be read, understood, and followed by the operating personnel. Goulds Pumps accepts no liability for damages or operating disorders which are the result of non-compliance with the operating instructions.

2. To avoid serious or fatal personnel injury or major property damage, read and follow all safety instructions in this manual.
3. Installation and maintenance **MUST** be performed by properly trained and qualified personnel.
4. Review all instructions and warnings prior to performing any work on the AquaBoost Controller.
5. Any safety decals **MUST** be left on the AquaBoost Controller unit and pump.

### Note

Inspect AquaBoost Controller for any damage after unpacking from shipping crates. Report any damage immediately to the carrier or distributor/dealer immediately.

6. In addition to instructions contained in this manual, you must meet any local safety, electrical, or plumbing codes and requirements. Installation, maintenance, or repair work must only be carried out by trained, skilled, and qualified personnel.
7. **The AquaBoost Controller drive head must be disconnected from the main power supply before attempting any operation in the electrical or mechanical part of the system.**

### Note

When in operation, the motor can be stopped, but power remains at the drive head. The motor and pump could start unexpectedly and produce serious injury. When the AquaBoost Controller drive head is connected to the main power supply, the inverter power supply and master control unit are also connected to the power supply.

**WARNING**



Hazardous voltage can shock, burn or cause death.

**WARNING!**

**FAILURE TO DISCONNECT ELECTRICAL POWER BEFORE ATTEMPTING ANY MAINTENANCE CAN CAUSE SHOCK, BURNS, OR DEATH.**

# Installation Procedures

## Step 1 – Pump / AquaBoost Installation

- 1) Refer to the pump manual for instructions on proper installation of the pump.
- 2) Mount the AquaBoost Controller on a wall in a well-ventilated area.
- 3) **Pressure Transducer Installation:** Locate the pressure transducer and cable. The threaded end of the transducer is 1/4" NPT. Install the transducer in the tee or on the downstream side of the check valve or foot valve.
- 4) **Connections in the Conduit Box:** (when using controller with other pumps) The free end of the motor cable should now be routed through the strain relief on the conduit box. Connect the motor leads using the motor nameplate as a reference. Place the thermistor terminal in the conduit box and fasten so that the sensor will contact the motor shell. **Note:** Step 4 is completed at the factory for complete AquaBoost pump kits with pumps.
- 5) **Input Power Cable Installation:** The cable has been pre-wired to the AquaBoost Controller. Cut the loose end to length, strip the wires and install the appropriate mating connector or wire directly to a junction box or distribution panel providing 208-230V, single phase power. An all leg disconnect switch should be provided. Follow local electrical codes and NEC.

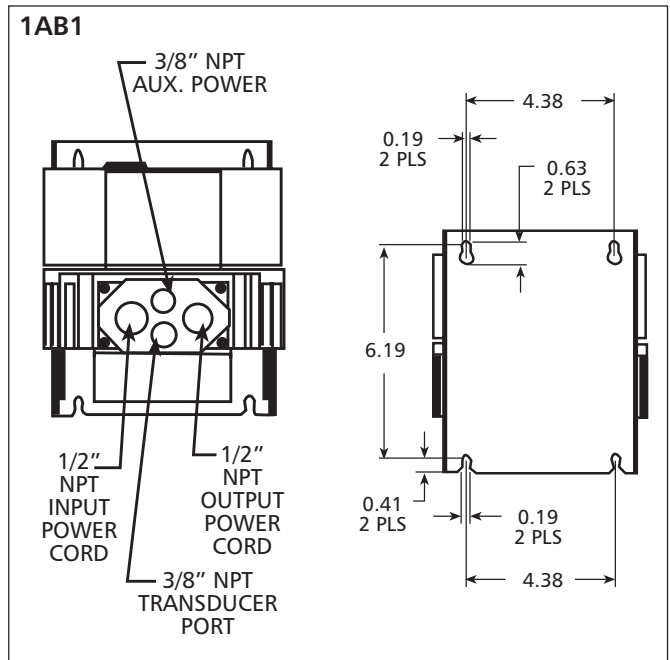

Diagram 3

**2AB1 and 3AB1**

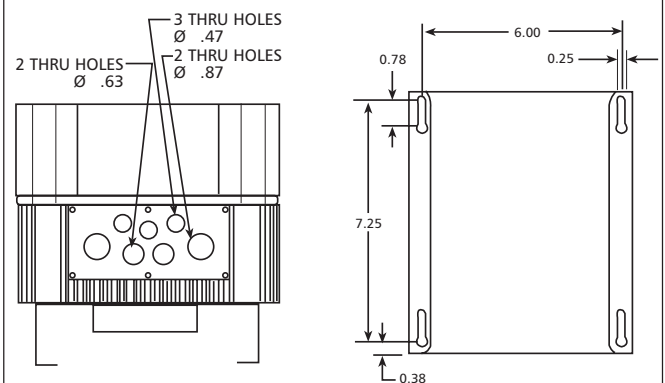
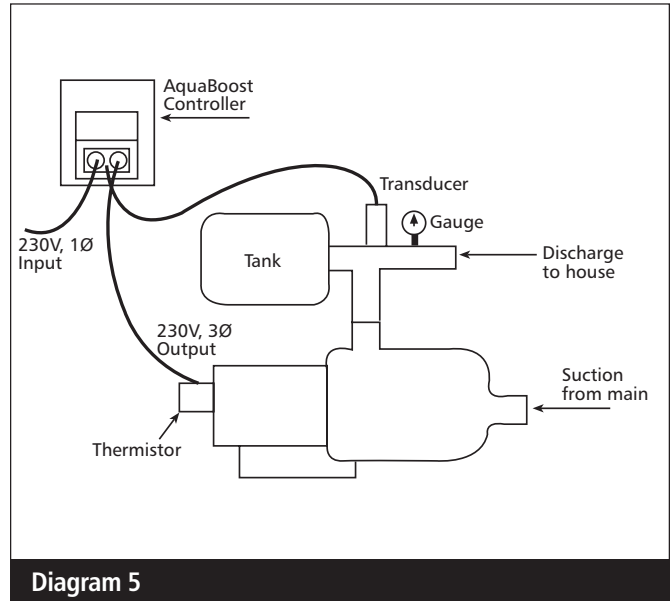

Diagram 4

# Installation Procedures

## Installation Configuration



## Step 2 – Electrical Connections



### WARNING!

FAILURE TO DISCONNECT AND LOCKOUT ELECTRICAL POWER AND WAIT FIVE MINUTES FOR CAPACITOR DISCHARGE BEFORE SERVICING AQUABOOST CONTROLLER CAN CAUSE SHOCK, BURNS, OR DEATH.

### Note

Installation and maintenance must only be performed by properly trained and qualified personnel equipped with the proper tools.



### WARNING!

- ⚠️ INSTALL, GROUND AND WIRE ACCORDING TO NATIONAL, STATE AND LOCAL CODE REQUIREMENTS.
- ⚠️ INSTALL AN ALL LEG DISCONNECT SWITCH NEAR THE MOTOR.
- ⚠️ DISCONNECT AND LOCKOUT ELECTRICAL POWER BEFORE INSTALLING OR SERVICING.

ELECTRICAL SUPPLY MUST MATCH PUMP'S AND AQUABOOST CONTROLLER NAMEPLATE SPECIFICATIONS. INCORRECT VOLTAGE OR WIRING CAN CAUSE FIRE DAMAGE, AND VOIDS WARRANTY.

MOTORS WITH AUTOMATIC THERMAL PROTECTION MAY OPEN THEIR ELECTRICAL CIRCUIT WHEN A THERMAL OVERLOAD EXISTS. THIS CAN CAUSE THE MOTOR TO START UNEXPECTEDLY AND WITHOUT WARNING.

# Installation Procedures

## Pump Priming



Refer to your pump operation manual for instructions on pump priming.

## Run Test





### WARNING

**DO NOT APPLY POWER TO THE AQUABOOST CONTROLLER OR PUMP UNTIL ELECTRICAL CONNECTIONS HAVE BEEN REVIEWED BY A QUALIFIED ELECTRICIAN AND MEET ALL APPLICABLE NATIONAL, STATE AND LOCAL CODE REQUIREMENTS.**

## Instructions



- 1) **Close discharge valve.** Make sure the discharge valve is closed. **Apply power to the AquaBoost Controller.**
- 2) Start the pump with the push button  on the front plate of the AquaBoost Controller.
- 3) Stop the pump after determining rotation by pushing the .
- 4) If rotation is incorrect, turn off all power to the AquaBoost, open the motor conduit box and exchange any two lead wires. Close the conduit box and reapply power.

## Change Pressure

- 1) Start the pump with the push button  on the front plate of the AquaBoost Controller.
- 2) Then press the  and  buttons together for more than 3 seconds.
- 3) The LED color changes to orange.
- 4) Now you could change the pressure with the  and  buttons. The set pressure is read off a gauge on the pump discharge.

### WARNING

**DO NOT SET THE REQUIRED PRESSURE FOR MORE THAN 80 PSI SINCE THIS CAN EXCEED THE CAPABILITY OF YOUR PLUMBING SYSTEM AND TANK. SERIOUS PROPERTY DAMAGE OR PERSONAL INJURY COULD RESULT.**

- 5) If there is no change to the setting for more than 5 seconds, the AquaBoost Controller returns to normal operation automatically, and the new required pressure is stored.
- 6) The pump can only be STARTED with the  button or STOPPED with the  button. Both buttons are on the front plate of the AquaBoost Controller.

## LED description

**Green Solid** – Motor is not running. The unit is stopped with the  button on the front plate.

**Green Slow Flashing** – Controller is active, but the motor has stopped.

**Green Fast Flashing** – Motor is running.

**Red Solid** – Error.

**Red Flashing** – Fatal error (AquaBoost Controller has to be disconnected from the power supply).

# Operator Displays

## Error Signals

The following conditions can cause a flashing red or solid red error light. If one of these error indications is visible, troubleshoot the system based on the following:

**Low Water Remedy:** Check suction pressure. If suction pressure is normal the unit restarts itself.

**Overheating – Motor** Possible causes: Insufficient cooling ambient temperature is too high, motor overloaded. After the cause has been remedied, the malfunction has to be reset by cutting off the power supply for > 30 seconds.

**Overvoltage** Possible cause: Check main supply, supply voltage too high, peak voltage due to switching heavy loads on the network. Find the cause and take countermeasures (e.g. line filter, RC-elements). Disconnect the power supply for > 30 seconds.

**Undervoltage** Possible cause: Check main supply, faulty fuse or out of phase.

**Overload** Possible causes: the pump is working at a capacity significantly in excess of its performance data. Disconnect the power supply for > 30 seconds.

**Overtemp. Heat Sink** The thermal sensor on the heat sink indicates over temperature. Possible causes: insufficient cooling, ambient temperature too high or motor overload. After remedy, cut off power for > 30 seconds to reset.

**Sensor Fault** A sensor signal of below .5 VDC was received due to bad sensor, broken cable or bad connection. After remedy cut off power for > 30 seconds to reset.

### Note

The above error displays can be viewed only with the external programmer (sold separately). This can be connected to the jack on the AquaBoost Controller for a more detailed analysis. Contact your local distributor for more information. Goulds Pumps Part Number: 2415241.

# Appendix A

## Pressure Transducer

The sensor of this transducer is a piezoresistive silicon pressure sensor, mounted on a tape (TAP) floating freely in an oil chamber. The pressure is transferred to the sensor by a separating nickel diaphragm in the oil chamber.

### Specifications

Range (FS): 10 Bar (147 psi) Gauge  
Over-pressure-Pmax: 300 psi  
Class of protection: IP 67

### Type

Signal Over Range: 0.5 - 4.5 V DC (ratiometric)  
Supply: 5 VDC +/- 0.25 VDC

### Sealed gauge:

### Supply:

+ VCC => red = supply voltage  
+ Out => white analog output signal  
GND => black ground

Operating Temperature: -20 - +80°C  
Storage Temperature: -40 - +100°C

Material: Body Steel and Brass  
Diaphragm: Nickel

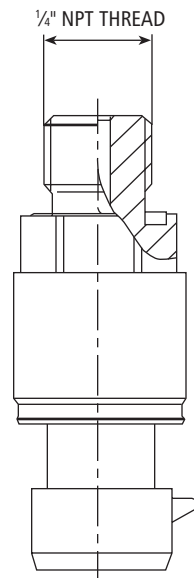

Pressure Transducer

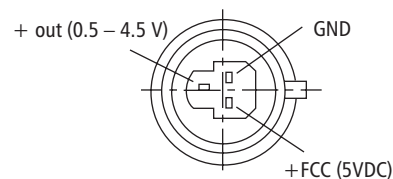

Plug

# Appendix B

## AquaBoost Controller Drive Head Technical Data

AquaBoost Controller		Supply	Motor		Voltage Protection
Type	Rated output	Voltage			
AV 1.1	1 HP	1 x 230 V / 40-60 Hz	3 x 230 V	4.8 A	10 Ampere
AV 1.15	2 HP	1 x 230 V / 40-60 Hz	3 x 230 V	7.0 A	10 Ampere
AV 1.2	3 HP	1 x 230 V / 40-60 Hz	3 x 230 V	10.0 A	16 Ampere

Input Voltage: 1 x 230 VAC  $\pm$  10% (An input line reactor is highly recommended for areas which experience voltage fluctuation.)

Output Voltage: 3 x 230 Volt AC

Max. Frequency: 40 – 60 Hz – selectable

Min. Frequency: 0 - f-max

Electrical Efficiency: > 95%

Protection against: Short circuit, under-voltage, overheating of the electronics (overload) and additional protective functions via external switch (motor temperature, low water).

A power supply filter is included to ensure interference immunity.

The AV Series frequency converter complies with the general EMV provisions and has been tested according to the following standards:

- Radio Interference Suppression EN 50081 Part 2 and EN 50082 Part 2
- High Frequency Field Interference ENV 50140 and ENV 50141
- Static Electricity Discharge EN 61000-4
- Disturbance Voltage EN55011

Ambient Temperature: 5° C – 40° C

Storage Temperature: -25° C – +55° C  
(+70° C during max. 24 hours)

Humidity: rH max. 50% at 40° C, unlimited  
RH max. 90% at 20° C, max. 30 days per year  
Condensation not permitted!

Air Pollution: The air may contain dry dust as found in workshops where there is no excessive quantity of dust due to machines. Excessive amounts of dust, acids, corrosive gases, salts, etc. are not permitted.

Class of Protection: UL, CUL, NEMA 4, IP 55

Altitude: Maximum 3000 feet above sea level. Consult factory for higher altitudes.



### GOULDS PUMPS LIMITED WARRANTY

This warranty applies to all water systems pumps manufactured by Goulds Pumps.

Any part or parts found to be defective within the warranty period shall be replaced at no charge to the dealer during the warranty period. The warranty period shall exist for a period of twelve (12) months from date of installation or eighteen (18) months from date of manufacture, whichever period is shorter.

A dealer who believes that a warranty claim exists must contact the authorized Goulds Pumps distributor from whom the pump was purchased and furnish complete details regarding the claim. The distributor is authorized to adjust any warranty claims utilizing the Goulds Pumps Customer Service Department.

**The warranty excludes:**

- (a) Labor, transportation and related costs incurred by the dealer;
- (b) Reinstallation costs of repaired equipment;
- (c) Reinstallation costs of replacement equipment;
- (d) Consequential damages of any kind; and,
- (e) Reimbursement for loss caused by interruption of service.

**For purposes of this warranty, the following terms have these definitions:**

- (1) "Distributor" means any individual, partnership, corporation, association, or other legal relationship that stands between Goulds Pumps and the dealer in purchases, consignments or contracts for sale of the subject pumps.
- (2) "Dealer" means any individual, partnership, corporation, association, or other legal relationship which engages in the business of selling or leasing pumps to customers.
- (3) "Customer" means any entity who buys or leases the subject pumps from a dealer. The "customer" may mean an individual, partnership, corporation, limited liability company, association or other legal entity which may engage in any type of business.

**THIS WARRANTY EXTENDS TO THE DEALER ONLY.**

Goulds Pumps, AquaBoost, Hydro-Pro and the ITT Engineered Blocks Symbol are registered trademarks and tradenames of ITT Industries.