

MODEL	PUMP	HP	TRIM	POWER	A	B	C	D	APPROX. WEIGHT (LBS)
5SH2A2A	5SH1K5E0	7.5	5 1/8"	230V / 1Φ	21	9 3/4	38 1/4	8"	2106
5SH2A2B	5SH1K5E0	7.5	5 1/8"	230V / 3Φ	21	9	38 1/4	8"	2106
5SH2A2C	5SH1K5E0	7.5	5 1/8"	460V / 3Φ	21	9	38 1/4	8"	2106
5SH2B2B	5SH1M5A0	15	6 7/8"	230V / 3Φ	21	9 1/2	38 1/4	8"	2228
5SH2B2C	5SH1M5A0	15	6 7/8"	460V / 3Φ	21	9 1/2	38 1/4	8"	2228
6SH2A2B	6SH1M5E0	15	6 3/8"	230V / 3Φ	23 3/4	10 3/4	39 3/4	10"	2824
6SH2A2C	6SH1M5E0	15	6 3/8"	460V / 3Φ	23 3/4	10 3/4	39 3/4	10"	2824
6SH2B2B	6SH1N5C0	20	6 15/16"	230V / 3Φ	23 3/4	11 3/4	39 3/4	10"	3368
6SH2B2C	6SH1N5C0	20	6 15/16"	460V / 3Φ	23 3/4	11 3/4	39 3/4	10"	3368
8SH2A2B	8SH1N5B0	20	7 3/4"	230V / 3Φ	21	10 3/4	39	8"	2808
8SH2A2C	8SH1N5B0	20	7 3/4"	460V / 3Φ	21	10 3/4	39	8"	2808
22SH2A2C	22SH1Q5F0	30	7 1/2"	460V / 3Φ	23 3/4	12 1/2	40 3/4	10"	3932

OPTIONS	
A	ALARM PACKAGE (RUN INDICATOR LIGHTS, PUMP FAILURE LIGHTS, ALARM HORN)
B	LINE REACTORS
C	LIGHTING ARRESTOR
D	SUCTION PRESSURE SWITCH
E	HIGH TEMP RELIEF VALVE ASSEMBLY
F	FLEX CONNECTORS

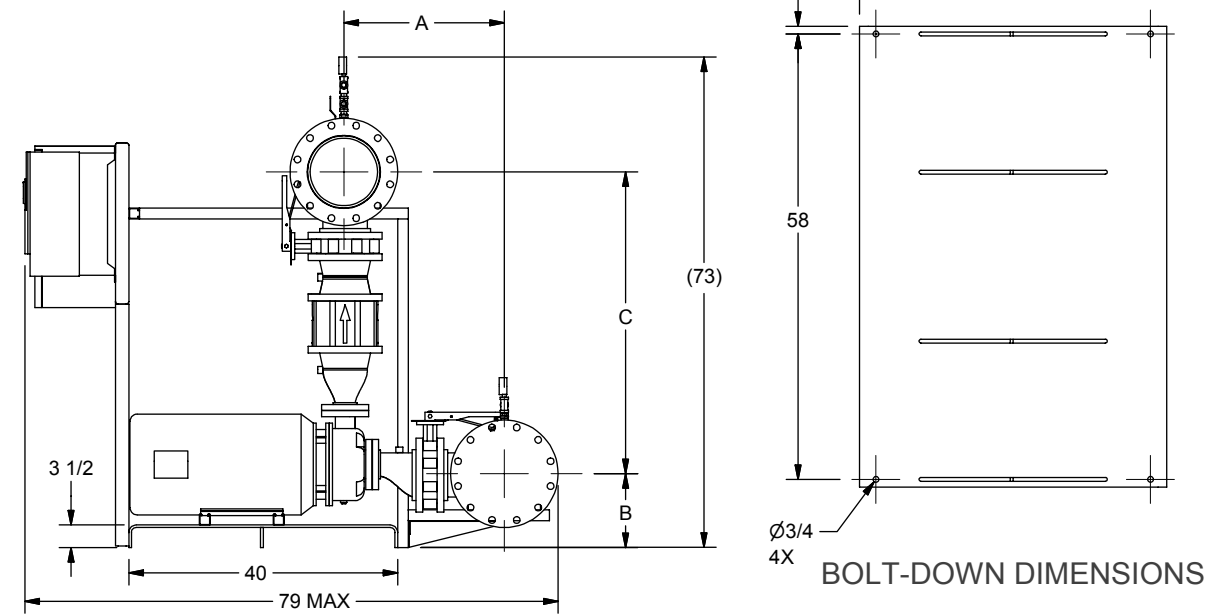
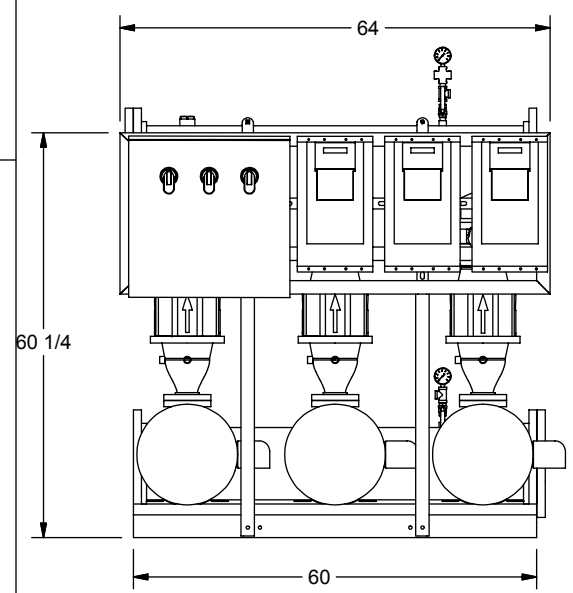

EXAMPLE MODEL NUMBER
5SH32A-AC
 BASIC MODEL NUMBER: 5SH32A
 OPTIONS: A - ALARM PACKAGE, C - SURGE ARRESTOR

- NOTES:
- STATION FLOW : _____ GPM
 MIN. SUCTION PRESSURE _____ + BOOST _____ = DISCHARGE PRESSURE: _____ PSI
 - ALLOW 5 PSI LOSSES THROUGH SYSTEM.
 - MANIFOLDS FLANGED BOTH ENDS TO ALLOW FOR CONNECTION TO EITHER END.
 - 48" CLEARANCE (CLEAR TO GROUND) REQUIRED IN FRONT OF CONTROL PANELS PER 2002 NEC TABLE 110-23(a) CATEGORY 3; USER ASSUMES ALL RESPONSIBILITY FOR EVALUATION OF SITE CONDITIONS IF USING CATEGORY 1 OR 2 CLEARANCES.
 - ALLOW 24" MIN. SERVICE CLEARANCE AROUND SYSTEM.
 - ALL DIMENSIONS ± 1/2".
 - NOT TO BE USED FOR CONSTRUCTION PURPOSES UNLESS CERTIFIED.

REV	ZONE	ID	DESCRIPTION	REV	ZONE	ID	DESCRIPTION	REV	ZONE	ID	DESCRIPTION

UNITS: INCHES

GENERAL TOLERANCES UNLESS NOTED OTHERWISE:
 INCHES: .020, .050
 MILLIMETERS: .50, .125

ANGLES ALL .5

GEOMETRIC TOLERANCES IN ACCORDANCE WITH ASME Y14.5M-1994 AND APPLICABLE GOULDS STANDARDS

THIRD ANGLE PROJECTION

DO NOT SCALE DRAWING

THIS DRAWING IS THE PROPERTY OF GOULDS PUMPS / ITT IND. SENECA FALLS, NY, USA AND SHALL NOT, EXCEPT UPON PRIOR WRITTEN PERMISSION OF GOULDS PUMPS / ITT IND., BE USED FOR ANY PURPOSE OTHER THAN THE MANUFACTURE OF ARTICLES FOR GOULDS PUMPS / ITT IND. DWG TO BE RETURNED UPON REQUEST.

SYMBOLS:
 // PARALLELISM
 ⊥ PERPENDICULARITY
 ∠ ANGULARITY
 ⊕ TRUE POSITION
 ↗ RUN OUT
 ↗ TOTAL RUN OUT (TIR)
 ⊙ CONCENTRICITY
 ▭ FLATNESS
 ▭ PROFILE

ITT Industries

PART

MODEL(S) SIZES

DRAWN	DATE	APPROVED	DATE	ORDER
MarkMartinez	3/18/2003			

CAD: AutoCAD DRAWING

PATTERN	MATERIAL	VOLUME	SCALE	SHEET
			1:30	1 of 1