

# ***Repair Parts*** *(for obsolete product)*

*Jets*

*Submersibles*

**JETS**

J03, J05, J03N, J05N .....	1
JS .....	2
JL07N, JL10N .....	3
GH .....	4
Primeflow .....	5
XSH .....	6
VA .....	7

**SUBMERSIBLES**

E .....	8
35LD, 48LE, 70LG .....	9
35CD, 48DE, 70FG .....	10
JRSG .....	11
JB .....	12
5-25GS (models with 2 cable guard screws) .....	13

The 10K2 has been replaced in production and as a repair part by the 10K10. The 10K10, John Crane Type 6, is a superior seal with a carbon rotary face, a ceramic stationary seat and BUNA N elastomers.

**Note:**

Goulds Pumps no longer sells brass tubing fittings or copper switch tubing. O-ring sealed elbow and straight connectors and plastic tubing has replaced them. The following chart should be used to select the correct kit for your pump. Kit prices are in the Jet & Submersible Price Book.

Kit Number	Description	Used On
6K119	(1) 90° elbow & (1) straight connector, tubing	BF, GH, J, J+, JS+, JL, SJ, VJ, VS
6K120	(2) 90° elbow connectors, tubing	CJ, HSJ, LJ, JB, JRS
JDW	(1) straight connector, (1) 6K2 pipe plug, tubing (Use on Deep Well jet pumps with pressure control valves)	GH, HSJ, J, J+, JS+, JL, SJ, VJ

**MODEL**

**J03, J05 tank mounted  
J03N, J05N Not Tank  
Mounted**

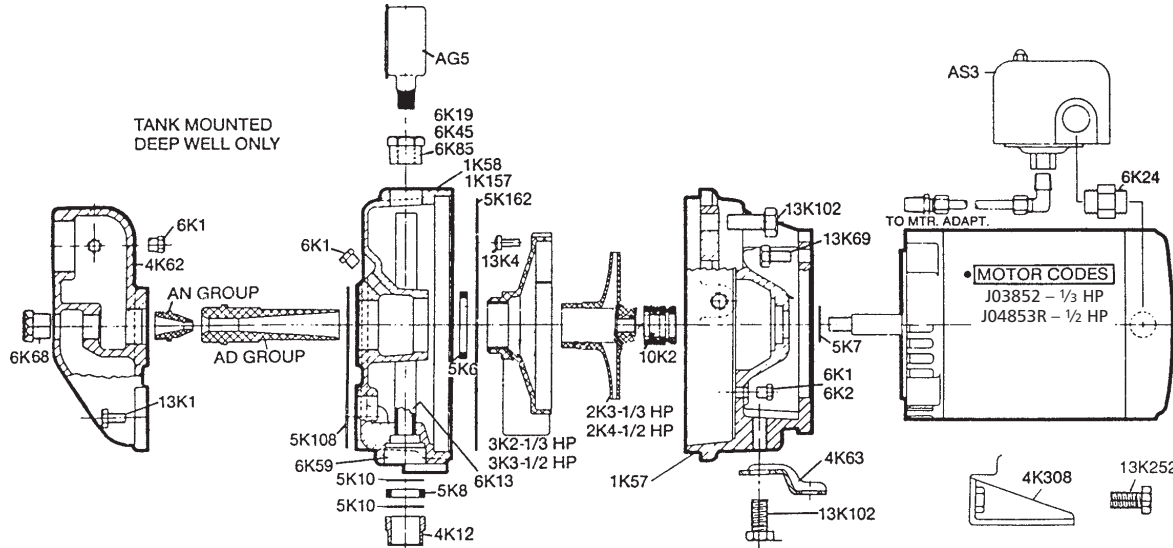

Part No.	Part Name	Pattern No.
1K57①	Motor adapter with 6K2 and foot	55178
1K58	Casing-tank mounted with 6K13, 1-6K1 and 1-6K2	55179
1K157 (was 1K59)	Casing-off tank with 1-6K1 and 1-6K2 use 1K311	55179
2K3	Impeller 1/2 HP	
2K4	Impeller 1/2 HP	
3K2	Guidevane 1/2 HP – use 3K61	
3K3	Guidevane 1/2 HP – use 3K75	
4K12	Discharge gland – tank mtd. only	55548
4K62	Shallow well adapter	
4K63	Foot	
4K308	Foot – new style	
5K6	Seal ring – guidevane	
5K7	Deflector	
5K8	Packing – discharge gland tank mounted only	
5K10	Washer – discharge gland tank mounted only	
5K108	Gasket – shallow well adapter	
5K162②	Gasket – casing	
6K1	Plug 1/2 NPT	
6K2	Plug 1/4 NPT	
6K12	Compression fitting – 1/4 pipe x 1/4 Tube	

Part No.	Part Name	Pattern No.
6K13	Discharge pipe – J03 & J05	
6K19	Reducing bushing 3/4 x 1/4	
6K24	Switch connector with nut	
6K45	Reducing bushing 1 x 1/4	
6K59	Bottom plug – for 1K58 off tank	
6K68	Plug 1/2 NPT shallow well only	
6K85	Reducing bushing 1 x 3/4	
10K2	Mechanical seal assembly	
13K1	Bolt – shallow well adapter	
13K4	Guidevane screw	
13K69	Bolt – adapter to motor	
13K71	Bolt – new style	
13K102	Bolt – casing and foot	
AA8-7③	Air charger (std. with 12 gal. and 30 gal. tank mounted only)	
ACA1	Galvanized tank 12 gallon – horizontal	
ACE1	Galvanized tank 30 gallon – horizontal	

Part No.	Part Name	Pattern No.
V45MP	Hydro-Pro™ tank	
V60MP	Hydro-Pro™ tank	
AG5	Pressure gauge	
AS3	Pressure switch	
AV15	Pressure control valve-off tank-deep well only	

**\* SHALLOW WELL NOZZLES AND VENTURIS**

HP	Unit	Nozzle	Venturi
1/2	Standard	AN015	AD 3726
1/2	High pressure	AN016	AD 3524
1/2	Standard	AN017	AD 3731
1/2	High pressure	AN019	AD 3528

\* See Water Systems Catalog Accessories Section.

- ① 1982 and later models: 1K57 motor adapters have 8 guidevane screw holes and will also fit 1982 and later series JL pumps. Earlier 1K57 motor adapters with 4 guidevane screw holes cannot be used on any JL model pump.
- ② 5K162 (2-port) gasket replaces 5K107 (single port) gasket. 5K162 gasket also fits 1982 and later series JL pumps. 5K107 (obsolete) gasket cannot be used on any series JL pump.
- ③ AA8-8 air volume control valve kit includes tubing and fittings.

**NOTE:** EFFECTIVE MARCH 1987 J AND JL CASINGS HAVE 1" NPT DISCHARGE. FOR USE WITH 3/4" PIPING. USE 1" NPT X 3/4" NPT REDUCING BUSHING PART NO. 6K85.

**JS** (1st version not JS+)

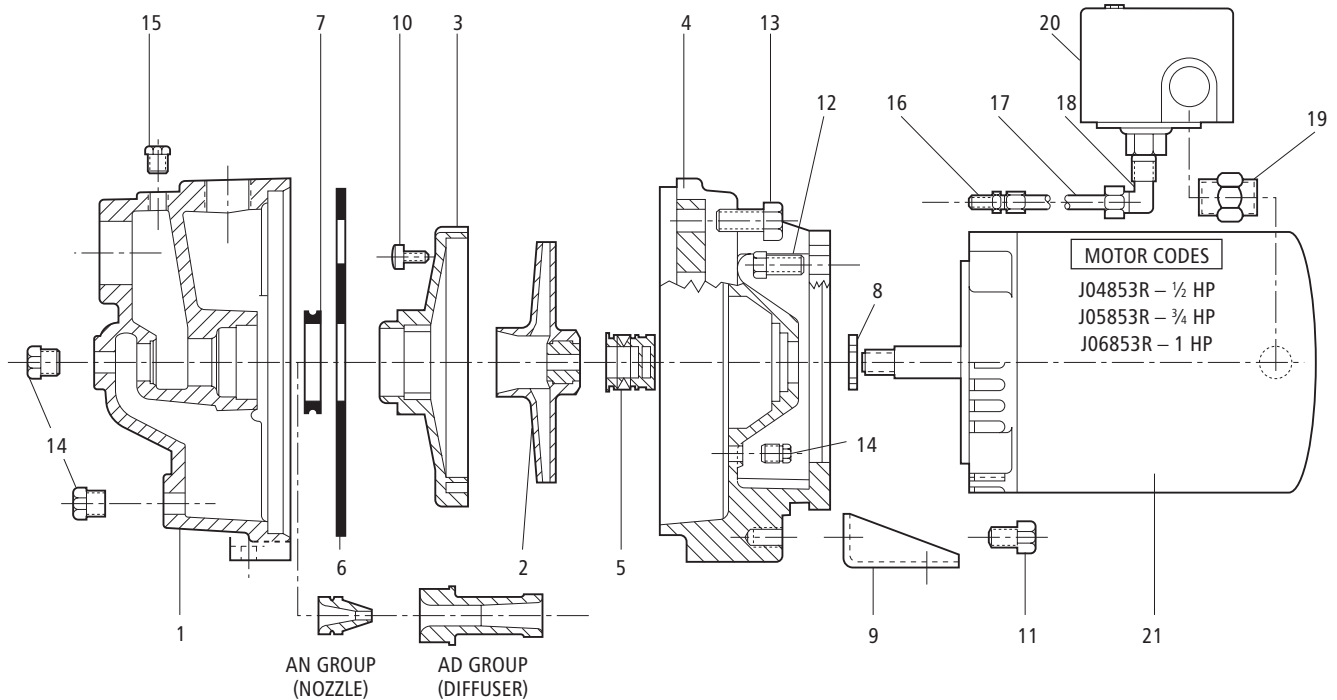

Item No.	Description	JS05 (H)	JS07	JS10
1	Casing	1K233 new style		
2	Impeller	2K4	2K60	2K61
3	Guidevane	3K75	3K52	3K52
4	Motor adapter	1K57 or use 1K310		
5	Shaft seal assembly	10K2		
6	Casing gasket	5K162		
7	Guidevane seal ring	5K6		
8	Deflector	5K7		
9	Foot	4K308		
10	Guidevane screw	13K4		
11	Bolt – foot to adapter	13K71		
12	Bolt – motor adapter to motor	13K69		
13	Bolt – motor adapter to casing	13K102		
14	Pipe plug – 1/4" NPT	6K2		
15	Pipe plug – 1/8" NPT	6K1		
16	Compression fitting – 1/4" x 1/4"	6K119		
17	Switch tubing			
18	Compression fitting elbow – 1/4" x 1/4"			
19	Switch connector with locknut	6K24		
20	Pressure switch	AS3FX*	AS4FX	
21	Motor	J04853R	J05853R	J06853R

**SHALLOW WELL NOZZLES AND VENTURIS**

HP	Unit	Nozzle	Venturi
1/2	JS05	AN017	AD3332
1/2	JS05H	AN019	AD3328
3/4	JS07	AN018	AD3336
1	JS10	AN018	AD3339

\* JS05H uses an AS4FX switch.

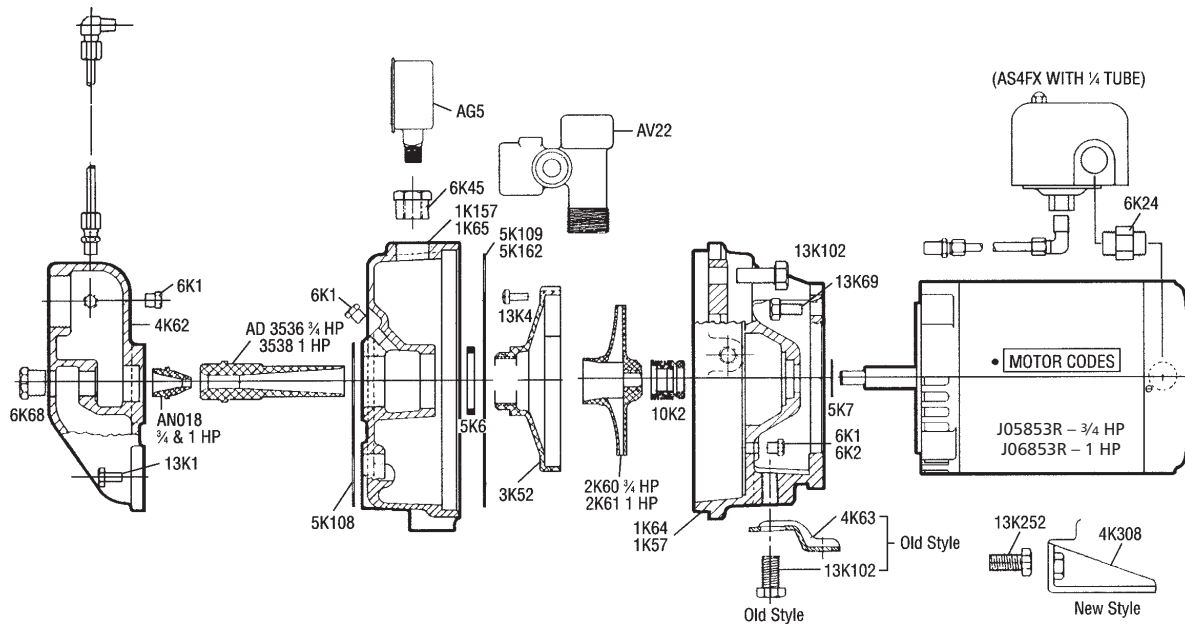

Part No.	Part Name	Pattern No.
Post '82 1K57① 1K157①	Motor adapter with plug and foot Casing with plugs	55178 55179
Pre '82 1K64① 1K65①	Motor adapter with plug and foot Casing with plugs	56604 56605
2K60 2K61	Impeller 3/4 HP Impeller 1 HP	
3K52	Guidevane	
4K62 4K63 4K308	Shallow well adapter Foot – old style Foot – new style	55548
5K6 5K7 5K108 5K109② 5K162②	Seal ring – guidevane Deflector Gasket – shallow well adapter Gasket – casing (1981 & earlier models) pattern 56605 Gasket – casing (1982 & later models) pattern 55179	
6K1 6K2 6K45 6K68	Plug 1/8 NPT Plug 1/4 NPT Reducing bushing (for AG5) 1 x 1 1/4 NPT Plug 1/2 NPT	

Part No.	Part Name	Pattern No.
6K24	Switch connector with nut	
10K2	Mechanical seal assembly	
13K1 13K4 13K69 13K102	Bolt – shallow well adapter Guidevane screw Bolt – adapter to motor Bolt – foot to motor adapter and motor adapter to casing	
13K252	Bolt – foot	
AD3536 AD3538	Venturi – shallow well – JL07N Venturi – shallow well – JL10N	
AG5	Pressure gauge	
AN018	Nozzle – shallow well only	
AS4FX AS6	Pressure switch (new style) Pressure switch (old style)	
AV22	Pressure control valve – deep well	
AA8-7③	Air volume control valve used with conventional galvanized tanks only	

New style – 1982 and later  
Old style – 1982 and earlier

- ① Check pattern number on parts.
- ② 5K162 gasket (2 oval ports) used on all 1982 and later JL pumps. 5K109 gasket (2 triangular ports) can only be used on 1981 and earlier series JL pumps.
- ③ AA8-8 air volume control valve kit includes tubing and fittings.

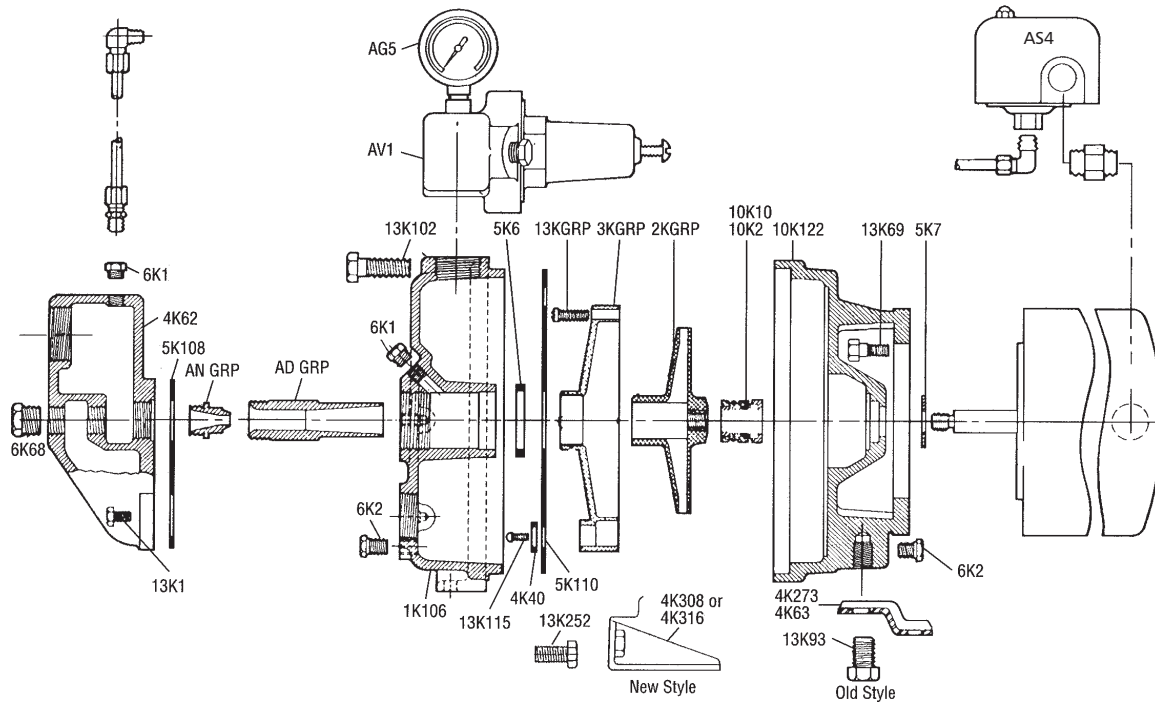

Part No.	Part Name	Pattern No.
1K106	Casing	57195
1K122	Motor adapter	57193
2K7	Impeller 1 HP – use 2K714	
2K8	Impeller 1½ HP – use 2K713	
2K29	Impeller ½ HP	
2K45	Impeller ¾ HP – use 2K716	
3K25	Guidevane ½ HP	
3K26	Guidevane ¾ HP	
3K27	Guidevane 1 HP & 1½ HP	
4K40	Guidevane flange	55548
4K62	Shallow well adapter	
4K63	Foot – motor adapter	
4K273	Foot – motor adapter 1½ HP	
4K308	Foot – new style	
4K376	Foot – motor adapter 1½ HP	
5K6	Seal ring – guidevane	
5K7	Deflector	
5K108	Gasket – shallow well adapter	
5K110	Diaphragm – casing	

Part No.	Part Name
6K1	Plug ¼ NPT
6K2	Plug ¼ NPT
6K68	Plug ½ NPT
10K2	Mechanical seal assembly ½-1 HP
10K10	Mechanical seal assembly 1½ HP
13K1	Bolt – shallow well adapter to casing
13K2	Screw – Guidevane 1 HP & 1½ HP
13K4	Screw – Guidevane ½ HP & ¾ HP
13K69	Bolt – Motor adapter
13K93	Bolt – foot
13K102	Bolt – casing
13K115	Screw – guidevane flange
13K252	Bolt – foot
AG5	Pressure gauge
AS4	Pressure switch ½ HP, ¾ HP, 1 HP, 1½ HP
AV1	Pressure control valve
AA8-7 <sup>ⓐ</sup>	Air volume control valve (for use with conventional galvanized tanks)

**SHALLOW WELL NOZZLES AND VENTURIS**

HP	Model	Nozzle AN GRP	Venturi AD GRP
½	GH05	AN012	AD3525
¾	GH07	AN014	AD3528
1	GH10	AN015	AD3532
1½	GH15	AN019	AD3538

ⓐ AA8-8 air volume control valve kit includes tubing and fittings.

**MOTOR CODES**

Model	Code	HP
GH05	J04853R	½ HP
GH07	J05853R	¾ HP
GH10	J06853R	1 HP
GH15	J07858R	1½ HP

**REPAIR PARTS**

Replaced by GT Irri-Gator™

Item No.	Part Description	Material	Repair Parts Number				
			PF07	PF10	PF15	PF20	PF30
1	¼ NPT pipe plug	Plated steel	6K2				
2	Casing	Cast iron	1K324				
3	Guidevane seal ring	BUNA	5K231				
		Viton	5K258				
4	Diaphragm	Neoprene	5K256				
		Viton	5K257				
5	Guidevane	Engineered Urethane	3K72	3K71	3K70	3K70	3K69
6	Impeller		2K715	2K716	2K714	2K713	2K712
7	Mechanical seal	Carbon/ceramic/BUNA	10K10				
		Carbon/ni-resist/EPR	10K18				
		Carbon/ceramic/viton	10K24				
		Carbon/tungsten/viton	10K55				
8	Pump foot	Steel	4K408				
9	Pump foot bolt	Steel	13K252				
10	Motor adapter	Cast iron	1K310				
11	Casing bolt	Steel	13K102				
12	Motor adapter bolt	Steel	13K69				
13	Deflector	BUNA	5K7				

**MOTOR CODES**

HP	1Ø-ODP	3Ø-ODP	1Ø-TEFC	3Ø-TEFC	1Ø-EXPRF	3Ø-EXPRF
.75	J05853R	C05873	C05821	C05876	BBC05825	BBC05875
1.0	J06853R	C06873	C06821	C06876	BBC06825	BBC06875
1.5	J07858R	C07878	C07821	C07876	BBC07825	BBC07875
2.0	J08854R	C08874	C08821	C08876	BBC08825	BBC08875
3.0	C09854	C09874	C09821	C09876	NA	NA

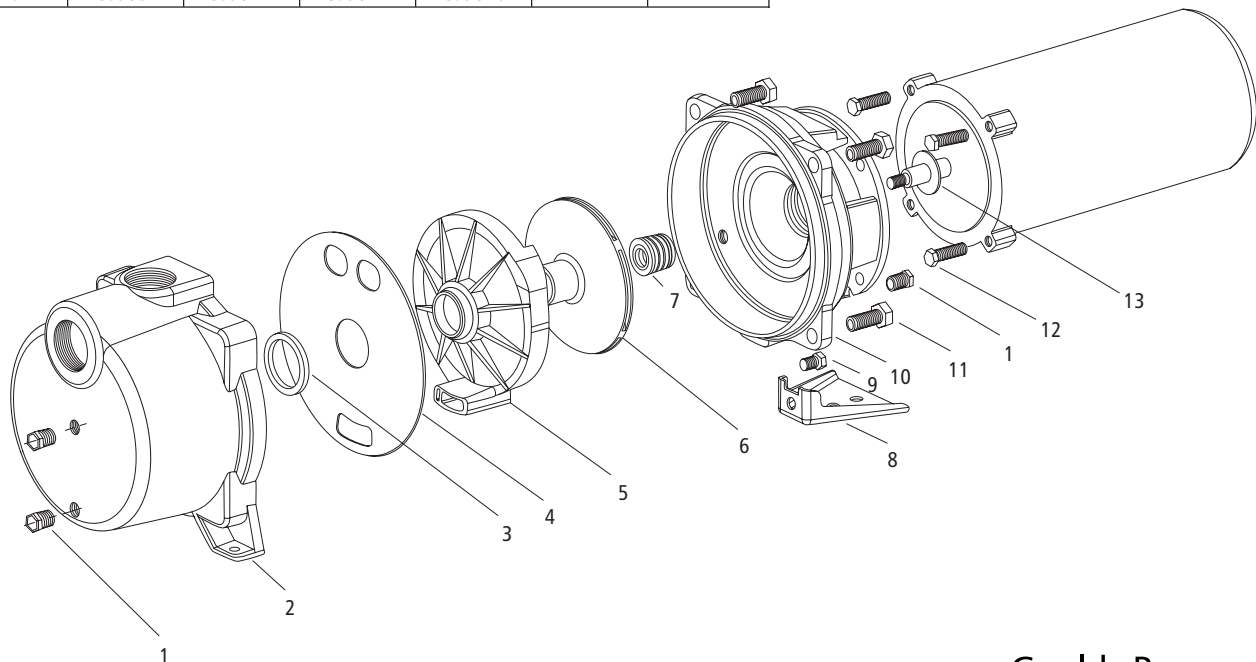

Goolds Pumps



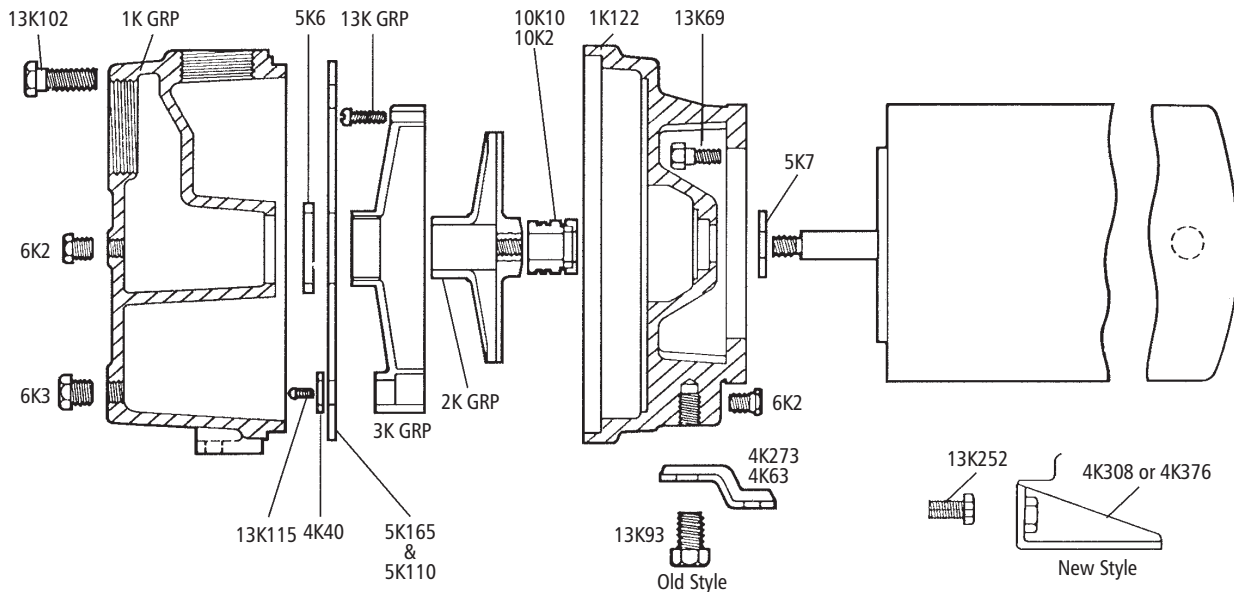

Part No.	Part Name	Pattern No.
1K104	Casing 1½"-¾" & 1 HP	57192
1K105	Casing 2"-1½" & 2 HP	57194
1K158	Casing 2"-3 HP	57194
1K122	Motor adapter	57193
2K7	Impeller ½ HP – use 2K714	55104
2K8	Impeller 2 HP – use 2K713	
2K45	Impeller 1 HP – use 2K716	
2K53	Impeller 3 HP	
2K114	Impeller ¾ HP – use 2K715	
3K25	Guidevane ¾ HP	59087
3K26	Guidevane 1 HP	
3K27	Guidevane 1½ HP & 2 HP	
3K60	Guidevane 3 HP	
4K40	Guidevane flange ¾-2 HP	
4K63	Foot – motor adapter ¾" & 1 HP-old style	
4K273	Foot – motor adapter 1½, 2 & 3 HP-old style	
4K308	Foot – new style ¾" & 1 HP	
4K376	Foot – new style 1½, 2 & 3 HP	

Part No.	Part Name	Pattern No.
5K6	Seal ring – guidevane	
5K7	Deflector	
5K110	Gasket – casing ¾-2 HP	
5K165	Gasket – casing 3 HP only	
6K2	Plug ¼ NPT – motor adapter	
6K3	Plug ¾ NPT – casing	
10K2	Mechanical seal assembly ½-1 HP	
10K10	Mechanical seal assembly 1½-3 HP	
13K2	Screw – guidevane 1½-3 HP	
13K4	Screw – guidevane ¾ HP & 1 HP	
13K6	Impeller locknut – 3 phase only	
13K69	Bolt – motor adapter to motor	
13K93	Bolt – foot to adapter	
13K102	Bolt – casing to adapter	
13K115	Screw – guidevane flange	
13K252	Bolt – foot	
AL27121	Loctite #271	

**Note:** Impellers on 3 HP three phase units are loctited to motor shaft. Impellers must be heated to be removed. When replacing impeller, use Loctite AL27121 – see instruction manual.

**MOTOR CODES**

Model	Order No.	HP
XSH07	J05853R	¾
XSH10	J06853R	1
XSH15	J07858R	1½
XSH20	①J08854R	2
XSH23	C08874	2 (3 Phase)
XSH30	J09853R	3
XSH33	C09874	3 (3 Phase)

①J08854L is now 230 V only – no 115 V.

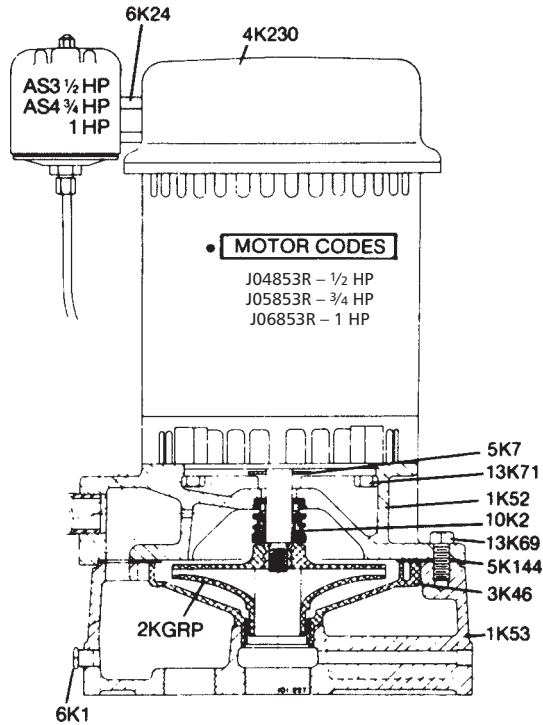

Part No.	Part Name	Pattern No.
1K52	Motor adapter	54337
1K53	Casing with guidevane and ring	
2K6	Impeller – ¾ HP	
2K7	Impeller – 1 HP	
2K28	Impeller – ½ HP	
3K46	Guidevane	
5K144	Gasket – casing	
①6K94	90° elbow connector	
①6K100	Straight connector	
①6K102	Tubing	
13K69	Hex cap screw – motor adapter to case	

① Use all new plastic parts together. Do not mix these with brass fittings and copper tubings.

**MODEL**

**E (4" Subs)**

Part	Current Models							
	HP	5ES	7EH	7E	10EJ	13EM	18E	25EL
Number of Stages	1/2	11	8	—	5	—	—	—
	1/2	15	11	—	7	5	—	—
	3/4	20	15	—	10	7	6	—
	1	25▲	20	—	12	10	8	7
	1 1/2	34▲	25▲	—	17	12	11	9
	2	—	—	27▲	20	17	14	11
	3	—	—	34▲	27s	21	19	15*
	5	—	—	—	—	—	30	26
1" Check valve		7K59	7K59	7K59	7K59②	—	—	—
1 1/4" Check valve		—	—	—	7K61②	7K61	7K61	7K61
Discharge head		7K60	7K60	7K859	7K859	7K859	7K859	7K859
Urethane bearing		7K860	7K860	7K860	7K860	7K860	7K860	7K860
Motor adapter with bearing		7K10	7K10	7K31	7K31	7K31	7K31	7K31
Shaft sleeve – lower		7K64	7K64	7K94	7K94	7K94	7K94	7K94
Bowl		7K7	7K7	7K478	7K478	7K478	7K858	7K18
Impeller		7K8	7K11	7K994	7K35	7K16	7K815	7K19
Diffuser		7K9	7K12	7K995	7K17	7K17	7K816	7K20
Bearing spiders		7K13	7K13	③	7K14	—	—	7K14
Bearing inserts		7K156	7K156	③	7K156	—	7K156	7K156
Centersleeves		7K209	7K209	7K209	7K209	—	7K209	7K209
Rubber bearing		7K26	7K26	7K26	7K26	7K26	7K26	7K26
Strainer		7K68	7K68	7K68	7K68	7K68	7K68	7K68
Impeller shim		7K155	7K155	7K155	7K155	7K155	7K155	7K155
Snap ring (pre 1982)①		7K208	7K208	—	7K208	7K208	—	7K208
Retaining ring①		7K817	7K817	7K817	7K817	7K817	7K817	7K817
Cable guard screw		13K91	13K91	13K91	13K91	13K91	13K91	13K91
Motor nut		13K114	13K114	13K114	13K114	13K114	13K114	13K114
Lock washer		13K117	13K117	13K117	13K117	13K117	13K117	13K117
Casing	1/2	7K483	7K482	—	7K544	—	—	—
	1/2	7K484	7K483	—	7K503	7K544	—	—
	3/4	7K485	7K484	—	7K505	7K503	7K846	—
	1	7K486	7K485	—	7K506	7K505	7K847	7K526
	1s	7K861	—	—	—	—	—	—
	1 1/2	—	7K486	—	7K508	7K506	7K848	7K527
	1 1/2▲	7K1178	7K861	—	—	—	—	—
	2	—	—	7K985	7K509	7K508	7K849	7K528
	3	—	—	7K993④	7K530	7K509	7K850	7K529
5	—	—	—	—	—	7K851	7K735	
Shaft assembly (includes hex shaft and coupling)	1/2	7K488	7K487	—	7K510	—	—	—
	1/2	7K489	7K488	—	7K511	7K510	—	—
	3/4	7K490	7K489	—	7K513	7K511	7K852	—
	1	7K491	7K490	—	7K514	7K513	7K853	7K532
	1s	7K862	—	—	—	—	—	—
	1 1/2	—	7K491	—	7K516	7K514	7K854	7K533
	1 1/2▲	7K1180	7K862	—	—	—	—	—
	2	—	—	7K988	7K517	7K516	7K855	7K534
	3	—	—	7K992⑤	7K1015	7K517	7K856	7K535
5	—	—	—	—	—	7K857	7K727	
Cable guard	1/2	7K493	7K492	—	7K518	—	—	—
	1/2	7K494	7K493	—	7K519	7K518	—	—
	3/4	7K495	7K494	—	7K521	7K519	7K865	—
	1▲	7K496	7K495	—	7K522	7K521	7K521	7K493
	1	7K740	—	—	—	—	—	—
	1 1/2▲	—	7K496	—	7K524	7K522	7K844	7K539
	1 1/2	7K1171	7K740	—	—	—	—	—
	2	—	—	7K983	7K525	7K524	7K495	7K540
	3	—	—	7K743	7K1017	7K525	7K740	7K541
5	—	—	—	—	—	7K845	7K743	

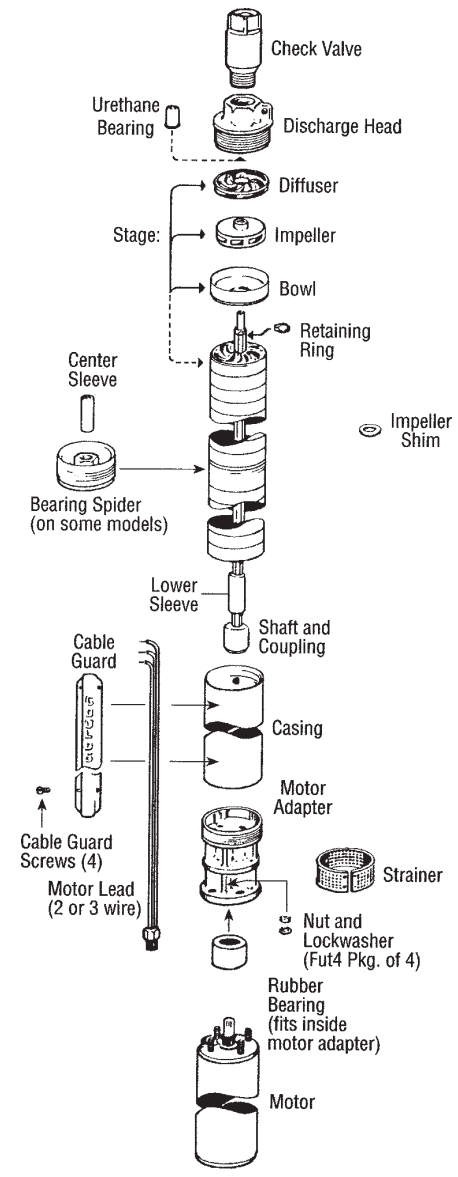

- ① Snap ring used on models built My 1982 and earlier. New style retaining rings used on models June 1982 and later (not interchangeable).
- ② 7K59 used on 10EJ for 1/2, 1, 1 1/2, 2 HP. 7K61 used on 10EJ for 1, 1 1/2, 2 HP.
- ③ 7E 2 HP bearing spider is 7K14 with 7K156 bearing insert; 3 HP bearing spider is 7K171 with 7K474 bearing insert.
- ④ 7E 3 HP – two casings required.
- ⑤ 7K992 is lower shaft assembly; Upper shaft assembly is 7K991; center coupling is 7K97.

▲ Indicates models with bearing spider, 5ES 1 HP 1983 and 7EH 1 1/2 HP 1983. Not counted in numbers of stages.

\* 22 stage model built prior to July 1981. Parts for 22 stage model: Casing – 7K530, Shaft Assembly – 7K536, Cable Guard – 7K542.

**4" High Capacity Submersibles**

Item No.	Part Description	Current Models			
		HP	35LD	48LE	70LG
	Number of stages	1½	7	4	–
		2	9	5	–
		3	13▲	8	7
		5	22▲	13▲	12▲
		7½	–	19▲	18▲
1	Motor adapter	7K1247	7K1247	7K1247	
2	Cover plate	7L318	7L318	7L319	
3	Diffuser	7L320	7L320	7L321	
4	Impeller	7L235	7L12	7L236	
5	Bowl ring	7L15	7L15	7L15	
6	Bearing spider	7L17	7L17	7L17	
7	Diffuser o-ring	7L322	7L322	7L323	
8	Cable guard screw	13K91	13K91	13K91	
9	Suction strainer screw	7L28	7L28	7L28	
10	Self-retaining fastener	7K1251	7K1251	7K1251	
11	Shaft bolt	7L29	7L29	7L29	
12	Shaft washer	7L237	7L237	7L237	
13	Shaft sleeve	7L324	7L324	7L324	
14	Thrust washer assembly	7L37	7L37	7L37	
15	Impeller spacer	7K1248	7K1248	7K1248	
16	Thrust plate	7K1249	7K1249	7K1249	
17	Hex nut Franklin Motor	13K114	13K114	13K114	
18	Lock washer	13K117	13K117	13K117	
19	Discharge head	7K1250	7K1250	7K1250	
20	Suction strainer	7L38	7L38	7L38	
21	Shaft and coupling	1½	7L325	7L329	–
		2	7L326	7L330	–
		3	7L327	7L331	7L333
		5	7L328	7L327	7L334
		7½	–	7L332	7L335
22	Cable guard	1½	7K241	7K1241	–
		2	7K1238	7K524	–
		3	7K1239	7K1242	7K1244
		5	7K1240	7K1239	7K1245
		7½	–	7K1243	7K1246
23	Casing	1½	7K1229	7K1232	–
		2	7K179	7K508	–
		3	7K1230	7K1233	7K1235
		5	7K1231	7K1230	7K1236
		7½	–	7K1234	7K1237

▲ Indicates model with intermediate bearing spider stage.

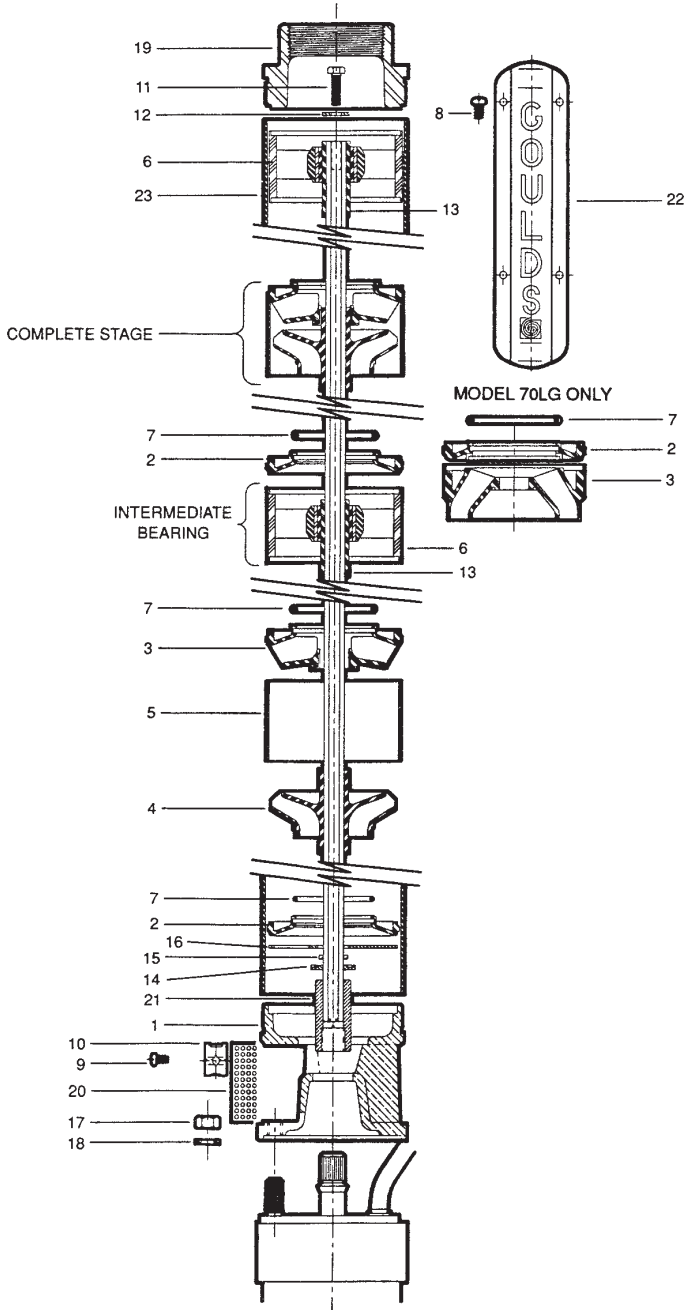

**MODEL**

**4" High Capacity Submersibles**

Item No.	Part Description	Current Models			
		HP	35CD	48DE	70FG
	Number of stages	1½	7	4	–
		2	9	5	–
		3	13▲	8	8
		5	22▲	13▲	13▲
		5R	–	–	12▲
		7½	–	19	19▲
		7½R	–	–	18▲
1	Motor adapter	7L1	7L1	7L1	
2	Cover plate	7L4	7L4	7L234	
3	Diffuser	7L7	7L7	7L257	
4	Impeller	7L235	7L12	7L236	
5	Bowl ring	7L15	7L15	7L15	
6	Spider assembly	7L17	7L17	7L17	
7	Discharge bowl ring	7L20	7L20	7L20	
8	Valve seat	7L21	7L21	7L21	
9	Check valve	7L22	7L22	7L22	
10	Discharge bowl seat	7L23	7L23	7L23	
11	Discharge bowl	7L31	7L31	7L31	
12	O-ring	7L25	7L25	7L25	
14	Cable guard screw	13K91	13K91	13K91	
15	Cable guard clamp and suction strainer screw	7L27 7L28	7L28	7L28	
16	Shaft bolt	7L29	7L29	7L29	
17	Shaft washer	7L237	7L30	7L237	
18	Shaft sleeve	7L32	7L32	7L32	
19	Bottom impeller spacer	7L36	7L36	7L34	
20	Thrust washer	7L37	7L37	7L37	
21	Suction strainer	7L38	7L38	7L38	
22	Lower plate	7L4	7L4	7L4	
23	Hex nut – Franklin Motors	13K114	13K114	13K114	
24	Lockwasher	13K117	13K117	13K117	
25	Power cable insulator	7L45	7L45	7L45	
26	Shaft and coupling	1½	7L238	7L67	–
		2	7L239	7L68	–
		3	7L70	7L69	7L242
		5	7L241	7L70	7L243
		5R	–	–	7L317
		7½	–	7L71	7L244
		7½R	–	–	7L316
27	Casing and discharge head	1½	7L245	7L92	–
		2	7L246	7L93	–
		3	7L95	7L94	7L248
		5	7L247	7L95	7L249
		5R	–	–	7L315
		7½	–	7L96	7L250
		7½R	–	–	7L314
28	Cable guard	1½	7L301	7L308	–
		2	7L296	7L306	–
		3	7L290	7L298	7L294
		5	7L283	7L290	7L311
		5R	–	–	7L313
		7½	–	7L285	7L282
		7½R	–	–	7L312
<b>Old Style</b>					
29	Lifting hook	7L26	7L26	7L26	
30	Cable guard clamp	7L27	7L27	7L27	
31	Cable guard screw	7L28	7L28	7L28	
32	Cable guard	1½	7L251	7L118	–
		2	7L252	7L119	–
		3	7L121	7L120	7L254
		5	7L253	7L121	7L255
		7½	–	7L122	7L256

▲ Indicates models with intermediate stage.  
**NOTE:** 70FG50RS has a 7L35 spacer in top stage.

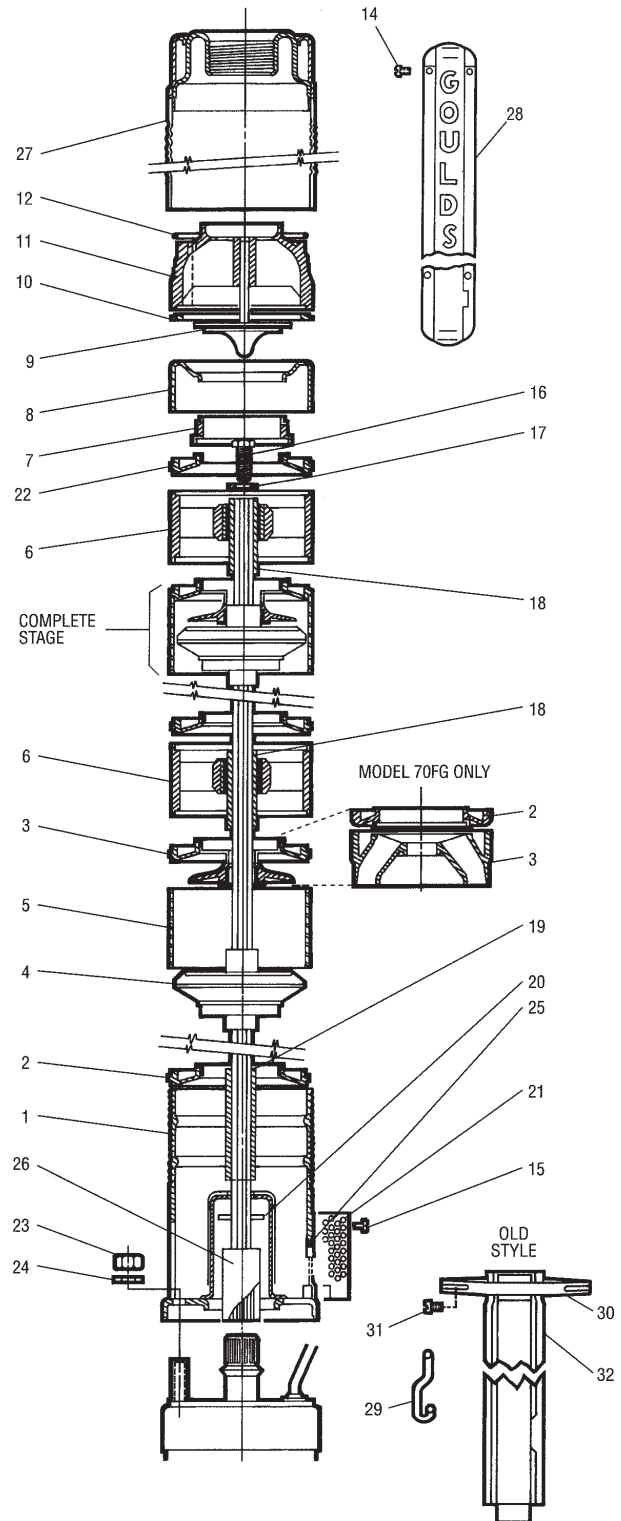

Goulds Pumps



**JRSG**

Item No.	Part Description	Material	Repair Part No.			
			JRS5G	JRS5GH	JRS7G	JRS10G
1	Drain plug ¼" NPT	Steel	6K2			
2	Vent plug ⅜" NPT	Steel	6K1			
3	Elbow connector – tubing	Polypropylene	6K94			
4	Casing	Cast iron	1K342			
5	Nozzle	Delrin®	AN018	AN020	AN018	AN018
6	Venturi tube	Lexan®	AD3330	AD3325	AD3336	AD3339
7	Separator plate seal ring	BUNA-N	5K6			
8	Separator plate	Polypropylene	5K253			
9	Diffuser (guidevane)	Lexan®	3K64	3K64	3K65	3K65
10	Impeller	Noryl®	2K4	2K4	2K60	2K61
11	O-ring	BUNA	5K230			
12	Mechanical seal – rotary	Teepelite	10K2			
13	Mechanical seal – stationary	Ceramic				
14	Seal housing	Amodel®	1K325			
15	Connector with locknut	Steel	6K24			
16	Pressure switch	NA	AS1			
17	Tubing – pressure switch	Polypropylene	6K93	6K93	6K108	6K108
18	Motor	Stainless steel shaft	SFJ04860EM	SFJ04860EM	SFJ05860EM	SFJ06860EM
19	Hex cap screw	Steel	13K80			
20	Grommet – base	BUNA	4K405			
21	Base	Steel	4K399			

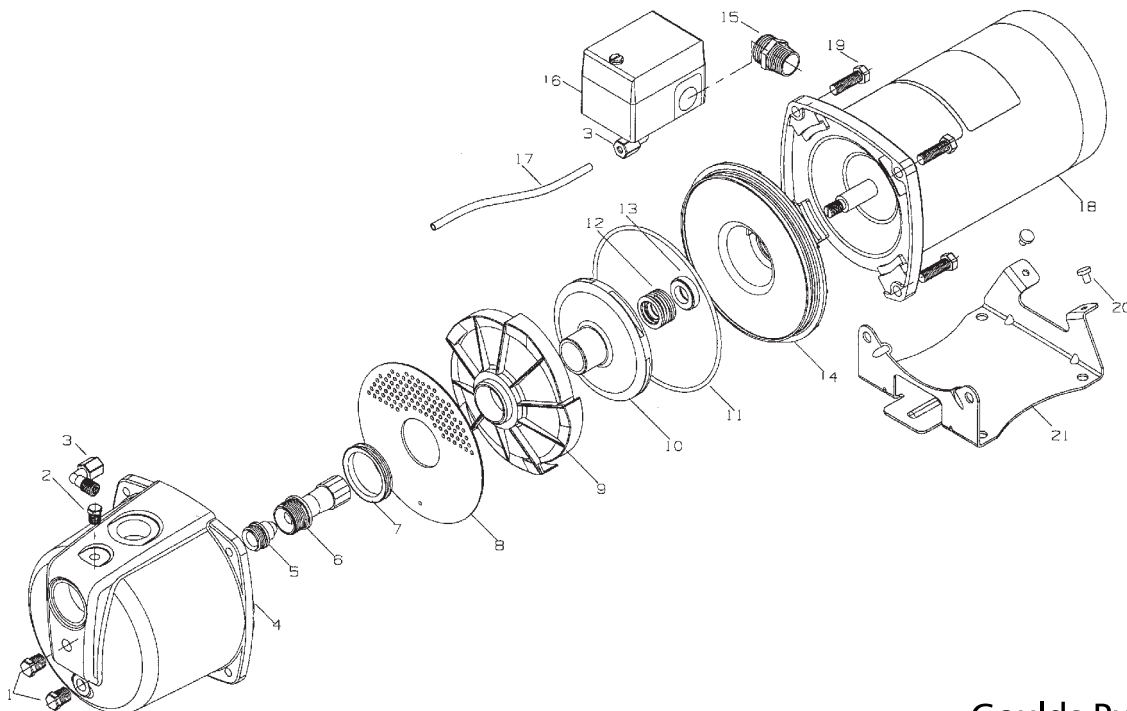

Item No.	Part Description	Material	Repair Part No.			Qty.	
			JB05	JB07	JB10		
1	Hex cap screw	Steel	13K194			2	
2	Shallow well adapter	Cast iron	4K400			1	
3	Deep well adapter	Cast iron	4K401			1	
4	Nozzle <sup>①</sup>	Delrin <sup>®</sup>	60 Hz	AN018		1	
			50 Hz	AN019			
5	Venturi Tube <sup>①</sup>	Lexan <sup>®</sup>	60 Hz	AD3330	AD3336	AD3339	1
			50 Hz	AD3328	AD3330	AD3332	
6	Gasket	BUNA	5K232			1	
7	Drain plug	Steel	6K2			1	
8	Elbow connector – tubing	Polypropylene	6K94			1	
9	Casing	Cast iron	1K304			1	
10	Separator plate seal ring	BUNA-N	5K6			1	
11	Separator plate	Polypropylene	5K253			1	
12	Diffuser (guidevane)	Lexan <sup>®</sup> 10% G.F.	3K64	3K65	3K65	1	
13	Impeller	Noryl <sup>®</sup> GFN2	2K4	2K60	2K61	1	
14	Mechanical seal – rotary	Teepelite	10K2			1	
15	Mechanical seal – stationary						Ceramic
16	O-ring	BUNA	5K230			1	
17	Seal housing	Cast iron	1K305			1	
18	Motor	SS shaft	SFJ04860	SFJ05860	SFJ06860	1	
19	Hex cap screw	Steel	13K80			4	
20	Tubing – pressure switch	Polyethylene	6K91	6K92	6K93	1	
21	Pressure switch	NA	AS1			1	
22	Connector with locknut	Steel	6K24			1	
23	Mounting base	Steel	4K399			1	
24	Grommet – base	BUNA	4K405			2	

① Nozzle, venturi tube combinations are for the shallow well pumps only.  
See deep well pump bulletin for deepwell combinations.

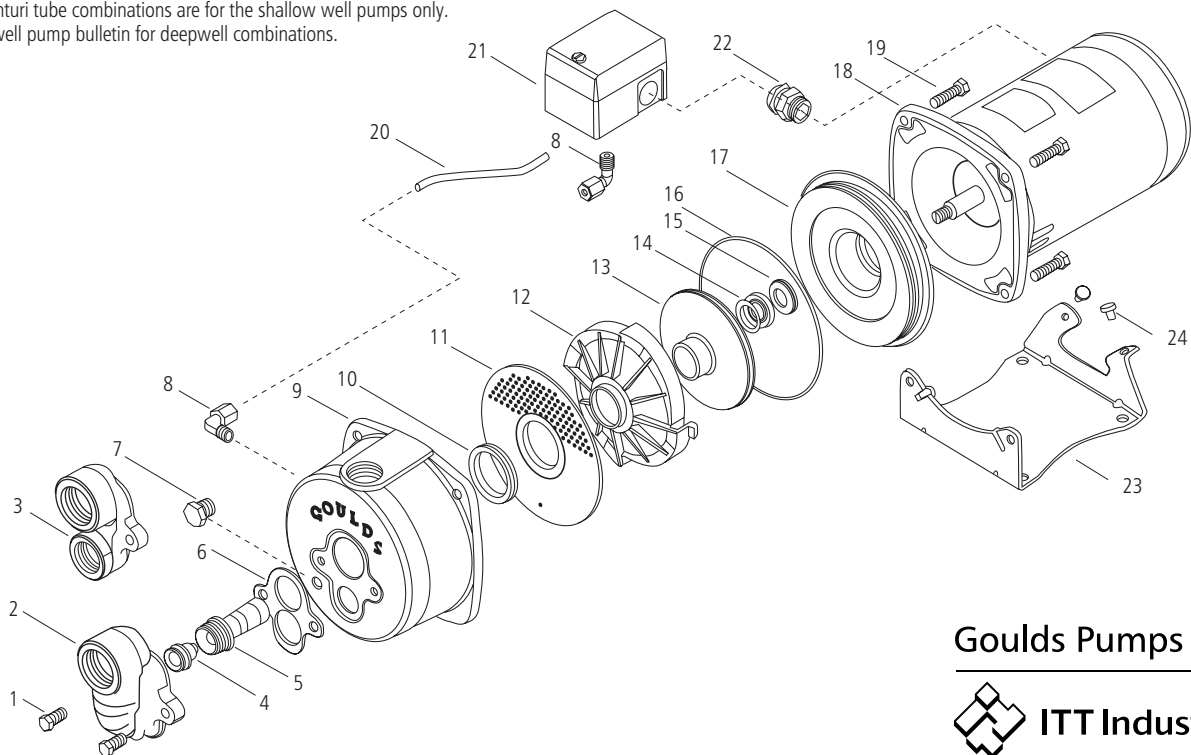

**MODEL**

**GS**

Item No.	Description	Models with only 2 Cable Guard Screws								
			5GS <sup>(H88)</sup>	5GS <sup>(H97)</sup>	Old Style 5GS <sup>④</sup>	7GS	10GS	13GS	18GS	25GS
	NUMBER OF STAGES } HORSEPOWER	1/2R	9	9	11	7	5	—	—	—
		1/2	12	12	15	10	7	5	—	—
		3/4	15	15	20	13	10	7	6	—
		1	20	20	25 <sup>①</sup>	17	12	10	8	7
		1 1/2	26	26 <sup>①</sup>	34 <sup>②</sup>	22	17	12	11	9
		2	—	—	—	27	20	17	14	11
		3	—	—	—	34 <sup>②</sup>	27 <sup>①</sup>	21	19	15
		5	—	—	—	—	42 <sup>②</sup>	—	30 <sup>①②</sup>	25 <sup>①⑤</sup>
1	Discharge head	7K1326								
2	Check valve poppet	7K1366								
3	Check valve seal	7K1368								
4	Check valve seat	7K1365								
5	C. V. retaining ring	7K1364								
6	Bearing spider – upper	7K1372								
7	Bearing	7K1740								
8	Shaft retaining ring - upper	7K817								
9	Diffuser	7K1750	7K9	7K995	7K17	7K20				
10	Impeller	7K1837	7K1749	7K8	SEE <sup>③</sup>	7K35	7K16	7K1334	7K19	
11	Bowl	7K1838	7K1751	7K7	7K478	7K858	7K18			
12A <sup>①</sup>	Int. shaft sleeve	7K209								
12B <sup>②</sup>	Int. shaft sleeve	—	—	7K1490	—	7K1490	—			
13A <sup>①</sup>	Int. bearing	7K1371	7K1501	7K1371	—	7K1371				
13B <sup>②</sup>	Int. bearing	—	—	7K1499	—	7K1499	—			
14 <sup>①②</sup>	Mid bearing	7K1369								
15	Shim	7K155								
16	Lower shaft sleeve	7K1336	7K1520	7K1336						
17	Inlet strainer	7K1370								
18	Screws – cable guard	13K91								
19	Motor adapter	7K1363								
20	Adapter ring	—	—	7K1500	—	—	—	—	—	
21	Spacer – mid (5GS15)	—	—	7K1552	—	—	—	—	—	
22 <sup>②</sup>	Shaft retaining ring – lower	7K1553								
23	Casing } HORSEPOWER	1/2R	7K1527	7K1429	7K1433	7K1429	7K1426	—	—	—
		1/2	7K1435	7K1430	7K1566	7K1433	7K1427	7K1426	—	—
		3/4	7K1840	7K1434	7K1442	7K1437	7K1431	7K1427	7K1429	—
		1	7K1841	7K1507	7K1508	7K1443	7K1434	7K1431	7K1431	7K1430
		1 1/2	7K1754	7K1753	7K1452 7K1509	7K1449	7K1440	7K1434	7K1437	7K1435
		2	—	—	—	7K1451	7K1444	7K1440	7K1441	7K1439
		3	—	—	—	7K1453	7K1450	7K1446	7K1448	7K1445
		5	—	—	—	—	7K1466 7K1636	—	7K1442 7K1638	7K1667
24	Shaft and coupling } HORSEPOWER	1/2R	7K1033	7K1361	7K1523	7K1361	7K1358	—	—	—
		1/2	7K1377	7K1374	7K1524	7K1376	7K1360	7K1358	—	—
		3/4	7K1831	7K1377	7K1383	7K1380	7K1375	7K1360	7K1359	—
		1	7K1458	7K1072	7K1388	7K1384	7K1377	7K1375	7K1374	—
		1 1/2	7K1839	7K1780	7K1519 7K1392	7K1389	7K1457	7K1377	7K1380	7K1378
		2	—	—	—	7K1391	7K1458	7K1457	7K1382	7K1381
		3	—	—	—	7K1462 7K1213	7K1390	7K1386	7K1387	7K1385
		5	—	—	—	—	7K1393 7K1221	—	7K1736 7K1737	7K1347
25	Cable guard } HORSEPOWER	1/2R	7K1400	7K1398	7K1403	7K1398	7K1396	—	—	—
		1/2	7K1405	7K1400	7K1525	7K1403	7K1397	7K1396	—	—
		3/4	7K1409	7K1404	7K1526	7K1406	7K1401	7K1397	7K1398	—
		1	7K1415	7K1424	7K1432	7K1413	7K1404	7K1401	7K1400	—
		1 1/2	7K1373	7K1755	7K1422	7K1419	7K1410	7K1404	7K1406	7K1405
		2	—	—	—	7K1421	7K1414	7K1410	7K1411	7K1409
		3	—	—	—	7K1423	7K1420	7K1416	7K1418	7K1415
		5	—	—	—	—	7K1635	—	7K1425	7K1659

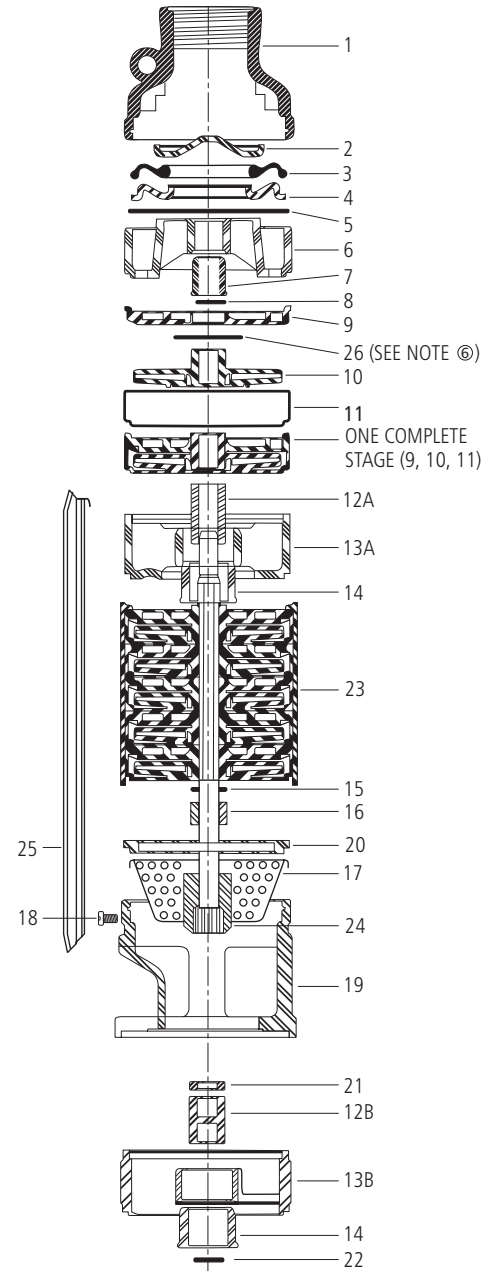

- ① Indicates model with one intermediate bearing, 18GS50 old style casing 7K1455, shaft and coupling 7K1395, cable guard 7K1425 (single casing design).
- ② Indicates model with split case pump.
- ③ For 1/2 HP – 1 1/2 HP use impeller 7K1343. For 2 HP – 3 HP use impeller 7K994.
- ④ Old style 5GS through G97, new design started H97.
- ⑤ Changed to 25 stages Nov. 1997 (L97). 26 stage casing 7K1454, shaft 7K1394, cable and coupling guard 7K1423.
- ⑥ For index number 26, use part no. 7K15 for the following models: 10GS20, 10GS30, 10GS50, 18GS50, 25GS50, 5GS15, 5GS20, 7GS20, 7GS30.

**Goolds Pumps**



