

60 Hz

Convertible Jet Pumps

1/2, 3/4, 1 and 1 1/2 HP

MODEL

J +

J5, J7, J10, and J15

APPLICATIONS

Specifically designed for:

- Homes
- Farms
- Cottages
- Booster service

SPECIFICATIONS

Pump:

- Pipe connections:
1 1/4" NPT suction
1" NPT discharge
1" NPT drive (pressure).
- Pressure switch: AS4FX preset at 30-50 PSI.

Motor:

- NEMA standard.
- 60 Hz.
- 1/2 – 1 1/2 HP, 115/230 V capacitor start.
- Single phase.
- 3500 RPM.
- Built-in overload with automatic reset.
- Stainless steel shaft.
- Rotation: clockwise when viewed from motor end.
- UL778 listed.

Maximum temperature: 140°F

FEATURES

■ **Convertible:** May be used on shallow or deep well applications using appropriate Goulds fittings. See the performance charts on the following pages for fitting order numbers.

■ Serviceable:

- Back pullout design allows disassembly of pump for service without disturbing piping.
- Two compartment motor for easy access to motor wiring and replaceable components.
- Nozzle clean out plug in shallow well adapter.
- Corrosion resistant, engineered plastic tubing and fittings are easily removed for cleaning. Premium O-ring design fittings need only be hand tight to seal.

■ **Impeller:** F.D.A. compliant, glass filled Noryl®. Corrosion and abrasion resistant.

■ **Diffuser (Guidevane):** Bolt down diffuser provides positive alignment with impeller. Diffuser also has stainless wear ring for extended performance in abrasive conditions. F.D.A. compliant, injection molded, food grade, glass filled Lexan® for durability and abrasion resistance.

■ **Tubing and Fittings:** F.D.A. compliant engineered plastic is corrosion and U.V. resistant.

■ Powered for Continuous Operation:

Pump ratings are within the motor manufacturer's recommended working limits. Can be operated continuously without damage.

■ Corrosion Resistant:

Electro-coated paint process is applied inside and out, then baked on.

■ Protected Mechanical Seal:

Special diaphragm design retains water in the casing at all times to ensure the mechanical seal can never run dry.

■ Excellent Air Handling Ability:

After initial priming the pump has the ability to re-prime itself even when air gets into the system. Pumping resumes once the water level rises above the foot valve.

SYSTEM COMPONENTS

■ **Basic Pump Unit:** Includes pump and motor, pressure gauge and bushing, pressure switch with tubing and fittings.

NOTE: THE TUBING COMES CONNECTED FOR SHALLOW WELL USE.

A DEEP WELL SET UP REQUIRES A JDW FITTINGS PACKAGE OR AN AV22 KIT. Both include additional fittings and a 24" tubing to connect to a pressure control valve.

ADDITIONAL COMPONENTS REQUIRED

■ Shallow Well Package:

Includes shallow well adapter, nozzle, venturi (diffuser), gasket, bolts, and pipe plugs

or

■ Deep Well Package:

Choose either a twin pipe or packer style.

- Twin pipe includes jet body, nozzle, venturi (diffuser) and foot valve.
- Packer includes packer body, nozzle, venturi (diffuser), and built-in check valve.

NOTE: Packer systems also require a packer adapter on the wellhead.

■ Deep well systems require a pressure control valve.

NOTE: YOU MUST HAVE A JDW OR AV22 KIT TO MAKE THE PRESSURE SWITCH CONNECTION.

■ Pressure tank required on all systems.

AGENCY LISTINGS



Canadian Standards Association



Underwriters Laboratories

Goulds Pumps is ISO 9001 Registered.



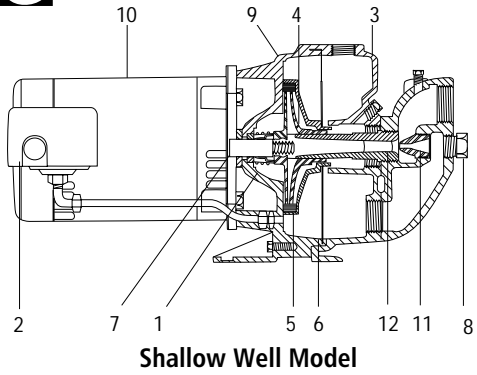

Shallow Well Model

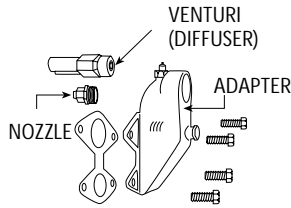

Shallow Well Package

MODEL

J +

J5, J7, J10, and J15

COMPONENTS

Item No.	Description
1	Mechanical seal
2	Pressure switch
3	Casing
4	Impeller
5	Diffuser (Guidevane)
6	Diaphragm
7	Stainless steel shaft
8	Nozzle clean-out plug
9	Motor adapter
10	Motor
11	Nozzle
12	Venturi (diffuser)

DIMENSIONS AND WEIGHTS

Model	J5	J7	J10	J15
Wt. (lbs.)	45	50	54	63
Length ①	16 1/2	17	17 1/2	20
Width	9 3/4			
Height	8 3/4			

(All dimensions are in inches and weights in lbs. Do not use for construction purposes.)

① Length is J+ pump and motor only. A shallow well adapter adds 4" to length.

SHALLOW WELL PERFORMANCE RATINGS

HP/Model	1/2 HP – J5					3/4 HP – J5					3/4 HP – J7					1 HP – J10					1 1/2 HP – J15									
Shallow Well Package	FH5					FH5H (High Pressure Model)					FH7					FH10					FH15									
Adapter	4K62																													
Nozzle	AN017					AN019					AN018					AN018					AN022									
Venturi	AD3731					AD3528					AD3536					AD3538					AD3542									
Total Suction Lift (feet)	Discharge Pressure – PSI						Discharge Pressure – PSI						Discharge Pressure – PSI						Discharge Pressure – PSI						Discharge Pressure – PSI					
	20	30	40	50	Max. Shut off (PSI)	20	30	40	50	60	Max. Shut off (PSI)	30	40	50	60	Max. Shut off (PSI)	30	40	50	60	Max. Shut off (PSI)	30	40	50	60	Max. Shut off (PSI)				
	Gallons per minute					Gallons per minute						Gallons per minute					Gallons per minute					Gallons per minute								
5	17.5	16.5	10.2	5.0	63	11.5	11.3	11.0	7.7	4.8	83	21.3	18.3	12.5	6.6	70	24.8	24.4	16.6	9.9	74	26.6	26.3	25.0	15.6	80				
10	15.7	14.4	9.2	4.3	61	10.3	10.0	9.6	7.0	4.2	81	18.8	17.3	11.3	5.0	68	22.9	22.2	15.8	8.6	72	24.7	24.3	22.6	13.9	77				
15	13.7	12.5	8.0	3.6	59	8.8	8.6	8.3	6.3	3.7	79	16.4	15.5	9.6	3.7	66	19.8	19.5	13.8	6.9	70	21.6	21.5	20.4	12.9	75				
20	11.5	10.4	7.1	2.3	57	7.0	7.0	6.8	5.8	3.2	76	13.6	13.2	8.3	2.0	63	16.6	16.6	12.2	5.6	67	18.1	18.0	17.6	12.0	73				
25	8.7	8.6	6.2	1.3	54	5.3	5.2	5.2	5.0	2.8	73	10.0	9.9	6.4	1.0	59	12.5	12.4	10.4	3.6	65	14.0	14.0	14.0	10.1	71				

MODEL

J +

J5, J7, J10, and J15

TWIN PIPE PERFORMANCE RATINGS

HP/Model		1/2 HP – J5				3/4 HP – J7				1 HP – J10				1 1/2 HP – J15				
Well Casing min. I.D.		4		4 1/2		4		4 1/2		4		4 1/2		4 1/2				
Pressure	Pipe Size (in.)	1		1 1/4		1		1 1/4		1		1 1/4		1 1/4				
		1 1/4		1 1/2		1 1/4		1 1/2		1 1/4		1 1/2		1 1/2				
① Jet Assembly Package		FT4-13	FT4-31	FT4-08	FT5-14	FT4-14	FT4-34	FT4-18	FT5-47	FT5-48	FT4-44	FT4-43	FT4-18	FT5-49	FT5-11	FT5-12	FT5-11	
Jet Body (only)		AT4		AT5		AT4		AT5		AT4		AT5		AT5		AT5		
Nozzle		AN017	AN016	AN015	AN018	AN017	AN016	AN016	AN018	AN017	AN017	AN017	AN016	AN019	AN018	AN019	AN018	
Venturi		AD726	AD723	AD720	AD724	AD729	AD725	AD722	AD730	AD725	AD730	AD727	AD722	AD732	AD727	AD734	AD727	
Control Valve Setting (PSI)		30	30	30	30	28	29	30	28	30	31	33	35	30	32	35	40	
Depth to Jet Assembly (based on submergence of 5 feet)	Feet	Gallons Per Minute (GPM) 30-50 PSI Pressure Switch Setting																
	30	13.0	11.0			15.8			16.6		17.0			19.3			21.2	
	40	11.8	9.0			15.7			16.0		16.6			18.0			20.0	
	50		7.6		6.9	13.2			15.0		14.4			16.0			16.1	
	60		7.0	5.2	6.4	10.2			13.0		11.5	11.2		14.3			15.0	
	70			4.7	5.6			8.2		11.0	10.0		9.3		12.6		14.0	11.2
	80			3.8	4.8			6.5		8.6		7.3	6.2	10.0	10.0		10.6	
	90			3.1	4.1			5.0	5.0	7.3			6.1		8.7		9.0	
	100								4.4	6.0			5.4		7.0		7.6	
	110								3.5	5.0			4.5		5.7		6.2	
	120														4.5		5.2	
	130																4.0	
	140																2.8	
	150																1.5	
	160																	
170																		

① Jet assembly package includes: jet body, nozzle, Venturi, and foot valve.

PACKER SYSTEM PERFORMANCE RATINGS

HP/Model		1/2 HP – J5					3/4 HP – J7				1 HP – J10				1 1/2 HP – J15			
Well Casing		2		3			2		3		2		3		3			
Suction	Pipe Size (in.)	1 1/4		1 1/2			1 1/4		1 1/2		1 1/4		1 1/2		1 1/2			
		FP2-13	FP2-31	FP2-08	FP3-36	FP3-24	FP2-40	FP2-47	FP3-53	FP3-54	FP2-48	FP2-43	FP3-55	FP3-14	FP3-16	FP3-18	FP3-21	FP3-24
Jet Body (only)		AP2		AP3			AP2		AP3		AP2		AP3		AP3			
Nozzle		AN017	AN016	AN015	AN021	AN018	AN015	AN015	AN018	AN017	AN016	AN019	AN018	AN019	AN021	AN023	AN018	
Venturi		AD726	AD723	AD720	AD730	AD724	AD727	AD723	AD730	AD725	AD729	AD725	AD732	AD727	AD735	AD723	AD731	AD724
Control Valve Setting (PSI)		30	30	30	30	30	32	27	30	35	36	28	32	34	34	34	39	
Depth to Jet Assembly (based on submergence of 5 feet)	Feet	Gallons Per Minute (GPM) 30-50 PSI Pressure Switch Setting																
	30	11.9	9.5		13.1			13.8		16.8		16.7		19.3			24.4	
	40	10.6	7.9		12.6			13.5		16.8		14.6		19.3			23.1	
	50		7.6		10.7	6.9		11.5		15.3		13.5		18.0			20.2	
	60		6.7	4.8	8.8	6.5		9.0	7.8	13.5		11.0	9.2	15.3		16.9	15.0	
	70			4.3	7.3	5.6			7.1	11.5	9.8		9.0	12.7			14.4	
	80			3.5		4.8			5.1		8.6		7.3	10.2		10.3	12.9	
	90								4.3		7.3		5.6		8.8		10.9	10.3
	100										6.2		4.2		7.2		9.6	7.3
	110										5.0				5.8		8.2	6.5
	120														4.5		6.9	5.8
	130																5.8	5.0
	140																4.7	4.5
	150																3.4	4.0
	160																	3.3
170																		

① Jet assembly package includes: jet body, Venturi, nozzle, built-in check valve, leather crimps, spacer and fitting.
Important: An offset of 50 feet will result in a decrease of about 25% from ratings as shown.

