



60 Hz

# Convertible Jet Pumps 1/2, 3/4 and 1 HP

**MODEL**

# JRD

JRD5, JRD7 and JRD10

## APPLICATIONS

Specifically designed for:

- Homes
- Farms
- Cottages
- Booster service

## SPECIFICATIONS

### Pump:

- Pipe connections:  
1" NPT discharge  
1 1/4" NPT suction  
1" NPT pressure.
- Pressure switch:  
AS4FX preset at 30-50 PSI.

### Motor:

- Standard NEMA service factors.
- 60 Hz
- 1/2 – 1 HP 115/230 V capacitor start.
- Single phase.
- 3500 RPM.
- Built-in overload with automatic reset.
- Stainless steel shaft.
- Rotation: clockwise when viewed from motor end.

Maximum temperature: 140°F.

## FEATURES

■ **Convertible:** May be used on shallow or deep well applications using appropriate Goulds Pumps fittings. See the performance charts on the following pages for fitting order numbers.

### ■ Serviceable:

- Back pullout design allows disassembly of pump for service without disturbing piping.
- Corrosion resistant, engineered plastic tubing and fittings are easily removed for cleaning. Premium O-ring design, fittings need only be hand tight to seal.

■ **Impeller:** F.D.A. compliant, glass filled Noryl®. Corrosion and abrasion resistant.

### ■ Diffuser (Guidevane):

F.D.A. compliant, injection molded, food grade, glass filled Lexan® for durability and abrasion resistance.

■ **Tubing and Fittings:** F.D.A. compliant engineered plastic is corrosion and U.V. resistant.

### ■ Powered for Continuous Operation:

Pump ratings are within the motor manufacturer's recommended working limits. Can be operated continuously without damage.

■ **Corrosion Resistant:** Electro-coated paint process is applied inside and out, then baked on.

### ■ Excellent Air Handling Ability:

After initial priming the pump has the ability to re-prime itself even when air enters the system. Pumping resumes once the water level rises above the foot valve.

## SYSTEM COMPONENTS

■ **Basic Pump Unit:** Includes pump and motor, pressure switch with tubing and fittings.

**NOTE: THE TUBING IS CONNECTED TO THE PUMP AT THE FACTORY.**

## ADDITIONAL COMPONENTS REQUIRED

■ **Shallow Well Package:** Includes shallow well adapter, nozzle, venturi and gasket

or

### ■ Deep Well Package:

Choose either a twin pipe or packer style.

- Twin pipe includes jet body, nozzle, venturi and foot valve.
- Packer includes packer body, nozzle, venturi and built-in check valve.  
NOTE: Packer systems also require an AWJ2 packer adapter on the wellhead.

■ Deep well systems require a pressure control valve.

**NOTE: You must have JDW or AV22KIT to make the pressure switch connection.**

■ Water system tank required on all systems.

## AGENCY LISTINGS



Canadian Standards  
Association  
LR38549

Goulds Pumps is ISO 9001 Registered.



# Convertible Jet Pumps 1/2, 3/4 and 1 HP

**MODEL**

## JRD

JRD5, JRD7 and JRD10

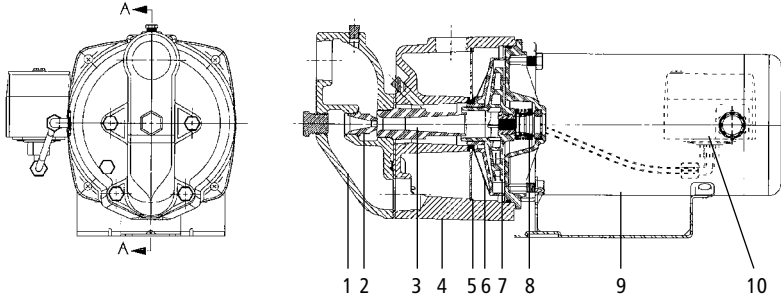
**COMPONENTS**

Item No.	Description
1	Shallow well adapter
2	Nozzle
3	Venturi
4	Cast iron casing
5	Separator plate
6	Diffuser (Guidevane)
7	Impeller
8	Mechanical seal
9	Motor
10	Pressure switch

**DIMENSIONS AND WEIGHTS – PUMP, MOTOR AND SHALLOW WELL ADAPTER**

Order No.	HP	Shallow Well Adapter	(Inches)			Wt. (lbs.)
			Length	Width	Height	
JRD5	1/2	FH5JRD	19	9 1/4	8 1/2	35
JRD7	3/4	FH7	19 1/2	9 1/4	8 1/2	37
JRD10	1	FH10	20 1/2	9 1/4	8 1/2	39

(All dimensions are in inches and weights in lbs. Do not use for construction purposes.)

**PERFORMANCE RATINGS – SHALLOW WELL**

HP/Order No.	1/2 HP – JRD5					3/4 HP – JRD7				1 HP – JRD10				
Shallow Well Package (includes the components below)	FH5JRD					FH7				FH10				
Adapter	4K62					4K62				4K62				
Nozzle	AN018					AN018				AN018				
Venturi	AD3731					AD3536				AD3538				
Total Suction Lift (feet)	Discharge Pressure – PSI					Discharge Pressure – PSI				Discharge Pressure – PSI				
	20	30	40	50	Max. Shut-off (PSI)	30	40	50	Max. Shut-off (PSI)	30	40	50	60	Max. Shut-off (PSI)
Gallons per minute						Gallons per minute				Gallons per minute				
5	12.3	12.0	9.0	4.0	63	19.0	16.5	10.5	69	22.0	21.0	15.0	8.0	72
10	11.0	10.8	7.6	3.0	62	16.0	14.5	9.0	67	18.5	18.0	12.5	6.5	70
15	9.2	9.0	6.5	2.5	60	13.5	13.0	7.0	65	16.0	15.5	11.0	5.0	68
20	7.6	7.5	5.5	1.5	57	12.0	11.5	5.5	63	13.3	13.0	9.0	3.0	65
25	5.7	5.5	4.0	.6	55	9.0	8.7	4.0	60	9.6	9.0	7.0	1.5	63

# Convertible Jet Pumps

## 1/2, 3/4 and 1 HP

**MODEL**

# JRD

JRD5, JRD7 and JRD10

**TWIN PIPE PERFORMANCE RATINGS**

HP/Order No.	1/2 HP – JRD5					3/4 HP – JRD7					1 HP – JRD10					
Well Casing Min. I.D. (in.)	3	4			4½	4			4½	4			4½			
Pressure Pipe Size (in.)	¾	1			1¼	1			1¼	1			1¼			
Suction Pipe Size (in.)	1	1¼			1½	1¼			1½	1¼			1½			
② Jet Assembly Package	FT3-09	FT4-13	FT4-31	FT4-08	FT5-14	FT4-14	FT4-34	FT4-18	FT5-47	FT5-48	FT4-44	FT4-43	FT4-18	FT5-49	FT5-11	
Jet Body (Only)	AT3	AT4			AT5	AT4			AT5	AT4			AT5			
Nozzle	AN015	AN017	AN016	AN015	AN018	AN017	AN016		AN018		AN017		AN016	AN019	AN018	
Venturi	AD722	AD726	AD723	AD720	AD724	AD729	AD725	AD722	AD730	AD725	AD730	AD727	AD722	AD732	AD727	
Control Valve Setting (PSI)	30										31	33	35	30	32	
	Feet	Gallons Per Minute (GPM) 30-50 PSI Pressure Switch Setting														
Depth to Jet Assembly (Based on Submergence of 5 Feet)	30	6.4	11.7	10.0			13.3			14.3		14.5			16.3	
	40	5.7	10.7	8.0			13.2			14.2		14.3			16.3	
	50	4.3	9.3	6.8			11.3			13.0		12.3			15.3	
	60			6.2	4.7		8.8	8.0		11.5		9.8	9.5		13.0	
	70			5.0	4.2	5.0		7.0		9.8	8.3		8.0		10.8	
	80				3.3	4.3		5.7			7.3		6.3	5.3	8.7	8.8
	90				2.8	3.7		4.2	4.5		6.3			5.2		7.5
	100								3.7		5.3			4.7		6.2
	110								3.0		4.3			3.8		4.8
	120															3.8

② Jet Assembly Package includes: Jet Body, Venturi, Nozzle, Foot Valve.  
**Important:** An offset of 50 feet will result in a decrease of about 25% from ratings as shown.

### PACKER SYSTEM PERFORMANCE RATINGS

HP/Order No.	1/2 HP – JRD5			3/4 HP – JRD7		1 HP – JRD10	
Well Casing	2						
Suction Pipe Size (in.)	1 1/4						
① Jet Assembly Package	FP2-13	FP2-31	FP2-08	FP2-40	FP2-47	FP2-48	FP2-43
Jet Body (Only)	AP2			AP2		AP2	
Nozzle	AN017	AN016	AN015	AN015		AN016	
Venturi	AD726	AD723	AD720	AD727	AD723	AD729	AD725
Control Valve Setting (PSI)	30			30	32	35	36
	Feet	Gallons Per Minute (GPM) 30-50 PSI Pressure Switch Setting					
Depth to Jet Assembly (Based on Submergence of 5 Feet)	30	10.7	8.5		11.8		14.2
	40	9.5	7.3		11.5		12.5
	50	8.3	6.7		9.8		11.5
	60		5.8	4.3	7.7	6.7	9.3
	70			3.8		6.0	7.7
	80			3.2		4.3	6.3
	90					3.7	4.8
	100						3.7
	110						
120							

① Jet Assembly Package includes: Jet Body, Venturi, Nozzle, Built-in Check Valve, Leather Crimps, Spacer and Fitting.

**Important:** An offset of 50 feet will result in a decrease of about 25% from ratings as shown.

### DIMENSIONS AND WEIGHTS – PUMP AND MOTOR

Order No.	HP	Length	Width	Height	Wt. (lbs.)
JRD5	1/2	15 3/4	9 1/4	8	30
JRD7	3/4	16 1/4	9 1/4	8	32
JRD10	1	17 1/4	9 1/4	8	34

Length is basic pump with no adapter.

(All dimensions are in inches and weights in lbs. Do not use for construction purposes.)

Goulds Pumps is a brand of ITT Water Technology, Inc.  
- a subsidiary of ITT Industries, Inc.

Goulds Pumps and the ITT Engineered Blocks Symbol are registered trademarks and tradenames of ITT Industries.