



293 Wright Street, Delavan, WI 53115

## OWNER'S MANUAL Pressurized Water Tanks

---



### **Installation/Operation/Parts**

*For further operating, installation,  
or maintenance assistance:*

**Call 1-262-728-9181**

	<b>Page</b>
Warranty.....	2
General Safety .....	3
Operation .....	4
Installation.....	4-7
Repair Parts .....	8
Xtended Warranty .....	9-11

**LIMITED WARRANTY**

Signature 2000 warrants to the original consumer of the products listed below, that they will be free from defects in material and workmanship for the Warranty Period from the date of original installation or manufacture as noted.

<u>Product</u>	<u>Warranty Period</u>
Signature 2000 4" Submersible Pumps	<i>whichever occurs first:</i> 1 year from date of original installation, or 2 years from date of manufacture
Signature 2000 Fibrewound Tanks	5 years from date of original installation

Our warranty will not apply to any product that has been subject to negligence, misapplication, improper installation or maintenance. In the event a three phase submersible motor is operated with single phase power through a phase converter, or if three-leg ambient compensated, extra-quick trip overload relays of recommended size are not used, our warranty is void.

Buyer's only remedy and Signature 2000's only duty is to repair or replace defective products (at Signature 2000's choice). Buyer agrees to pay all labor and shipping charges associated with this warranty and to request warranty service through the installing dealer as soon as a problem is discovered. If warranty service is requested more than 30 days after the Warranty Period has ended, it will not be honored.

**SIGNATURE 2000 SHALL NOT BE LIABLE FOR ANY CONSEQUENTIAL, INCIDENTAL, OR CONTINGENT DAMAGES WHATSOEVER.**

**THE FOREGOING WARRANTIES ARE EXCLUSIVE AND IN LIEU OF ALL OTHER EXPRESS WARRANTIES. IMPLIED WARRANTIES, INCLUDING BUT NOT LIMITED TO THE IMPLIED WARRANTIES OF MERCHANTABILITY AND FITNESS FOR A PARTICULAR PURPOSE, SHALL NOT EXTEND BEYOND THE WARRANTY PERIOD PROVIDED HEREIN.**

Certain states do not permit the exclusion or limitation of incidental or consequential damages or the placing of limitations on the duration of an implied warranty, therefore, the limitations or exclusions herein may not apply. This warranty sets forth specific legal rights and obligations, however, additional rights may exist, which may vary from state to state.

Supersedes all previous publications.

**Signature 2000, 293 Wright St., Delavan, WI 53115**

## READ AND FOLLOW SAFETY INSTRUCTIONS!

**⚠ This is the safety alert symbol.** When you see this symbol on your pump or in this manual, look for one of the following signal words and be alert to the potential for personal injury:

**⚠ DANGER** warns about hazards that **will** cause serious personal injury, death or major property damage if ignored.

**⚠ WARNING** warns about hazards that **can** cause serious personal injury, death or major property damage if ignored.

**⚠ CAUTION** warns about hazards that **will** or **can** cause minor personal injury or property damage if ignored.

The label **NOTICE** indicates special instructions which are important but not related to hazards.

**Carefully read and follow all safety instructions in this manual and on pump.**

Keep safety labels in good condition.  
Replace missing or damaged safety labels.

## RULES FOR SAFE INSTALLATION AND OPERATION

1. Read the Owner's Manual and Rules for Safe Operation and Installation Instructions carefully. Failure to follow these Rules and Instructions could cause serious bodily injury and/or property damage.
2. Install system according to local codes.
3. Always test water from well for purity before using. Check your local health department for testing procedure.
4. Before installing or servicing your tank, BE SURE pump electric power source is disconnected.
5. Release all pressure before working on tank or system. Make sure all air pressure has been released before removing tank flanges.
6. BE SURE your pump electrical circuit is properly grounded.
7. Remove bleeder orifices, air volume controls or other air charging devices in existing system.

**⚠ WARNING** To prevent possible serious or fatal injury and/or damage to equipment, system pressure must be less than 100 pounds per square inch (PSI) under any circumstances. Failure to follow this instruction can result in tank explosion. If system discharge pressure can exceed 100 PSI, install a relief valve capable of passing the full pump volume at 100 PSI. Install relief valve in pump supply line to tank, as close to tank as possible.

**⚠ WARNING** Hazardous pressure. Read owner's manual before attempting to install, operate, or service this tank. To avoid possible equipment failure, severe injury, and property damage, do not allow pump, tank, or piping system to freeze.

## GENERAL SAFETY

All tanks are factory pre-charged with air to 40 pounds per square inch (PSI). When installing tank, reduce pre-charge to 2 PSI below pump cut-in pressure setting. To do this, bleed air from valve on top of tank.

**NOTICE:** Always set pre-charge with NO WATER in tank.

Check pressure frequently with an accurate tire pressure gauge until correct pressure has been reached. For correct pre-charge pressure settings, see Chart 1, below.

### CHART I

Pressure Switch Setting	Tank Precharge (PSI)
20-40 PSI	18
30-50 PSI	28
40-60 PSI	38
50-70 PSI	48

**NOTICE:** Replace and tighten air valve cap if it is removed for any reason. Failure to replace air cap may allow loss of air pressure and eventually lead to tank waterlogging and air cell failure.

Pre-charged storage tanks can be connected together to increase the supply of usable water (drawdown). Two tanks of the same size will double the supply and three tanks will triple the supply. See Figures No. 1A and 1B for typical installations of this kind.

**NOTICE:** Tanks shipped outside continental U.S.A. are not precharged.

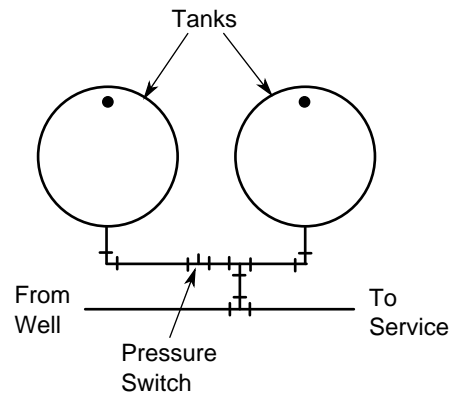

**Figure 1A: Typical Layout With Two Tanks**

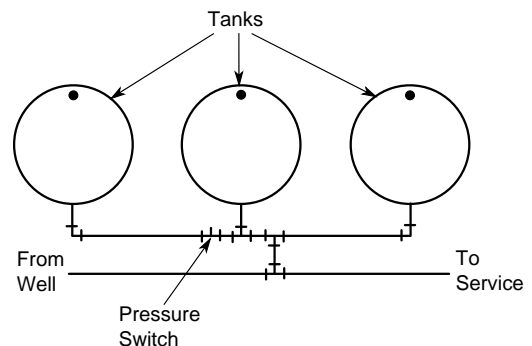

**Figure 1B: Typical Layout With Three Tanks**

## OPERATING CYCLE:

1. Tank nearly empty – air expands filling area inside air cell (Figure 2A).
2. Water begins to enter tank – air is compressed in air cell as tank fills with water (Figure 2B).
3. Pump-up cycle completed – air pressure has reached the cut off setting of pressure switch (Figure 2C).
4. Water being drawn from tank – compressed air in air cell forces water out of tank (Figure 2D).

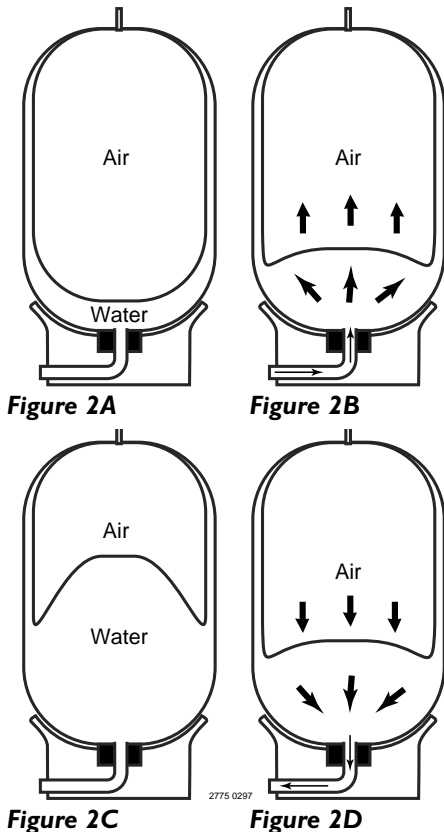

Figure 2: Air Cell Cycle

5. Tank now empty – new cycle ready to begin (Figure 2A).

## Chart II – Water Yield Per Pump Cycle (drawdown) in Gallons

Model	Pressure Switch Setting (PSI)		
	20-40	30-50	40-60
SR20-6S	6.9	5.9	5.2
SR35-10S	12.1	10.3	9.0
SR40-12S	13.8	11.8	10.3
SR48-14S	16.5	14.2	12.4
SR60-18	20.7	17.7	15.5
SR85-25	29.3	25.1	21.9
SR119-35	41.1	35.1	30.7

**NOTICE:** Drawdown will be affected by operating temperature of the system, accuracy of the pressure switch and gauge, the actual precharge pressure, and the rate of fill.

## INSTALLATION

Connect system pipe to elbow on tank flange. Use plastic or steel pipe as required. To prevent leaks, use Teflon tape or Plasto-Joint Stik<sup>1</sup> on male threads of all threaded connections to tank.

**NOTICE:** To be sure that joint is not cross-threaded and that threads are clean, always make connections by hand (without sealer) first. After making sure that threads are clean, remove pipe, add Teflon tape or Plasto-Joint Stik, and remake connection. Do not over-tighten pipe connection at tank. Thread connection on by hand until hand tight.

**NOTICE:** When replacing a standard tank in a submersible pump system, raise pump and discharge pipe far enough to remove bleeder orifices from the tees in the discharge pipe. Plug the tees. When replacing a standard tank in a jet pump system, remove Air Volume Control (AVC) and plug AVC port in pump.

<sup>1</sup>Lake Chemical Co., Chicago, Illinois

## SPECIFICATIONS

Model	Maximum Capacity U.S. Gallons	Tank Diameter	Tank Height	Service Clearance	Tank Discharge Tapping
SR20-6S	20	16"	36"	48"	1"
SR35-10S	35	20"	39-1/2"	51"	1"
SR40-12S	40	16"	60-1/2"	72"	1"
SR48-14S	48	20"	50-1/4"	62"	1"
SR60-18	60	24"	45-3/4"	57-3/4"	1-1/4"
SR85-25	85	24"	59-1/2"	77-1/2"	1-1/4"
SR119-35	119	28"	62-1/4"	80-1/4"	1-1/4"

**NOTICE:** Maximum Internal Water Temperature – 120° F.  
 Maximum Ambient Air Temperature – 125° F.  
 Distance from base to center line of connection is 2-1/2".  
 Allow 12" clearance over top of 20, 35, 40, 48 and 60 gallon tanks for service access.  
 Allow 18" clearance above 85 and 119 gallon tanks.

In areas where the temperature is high for long periods of time, the tank pre-charge pressure may increase. This may reduce the tank drawdown (amount of water available per cycle). If this occurs, reduce the pre-charge pressure to two PSI below the pump cut-in setting of the pressure switch.

It is necessary to flush all air out of the piping system and water reservoir portion of the pre-charged tank. This is required on new installations, pumps requiring repriming and pumps that have been disassembled for service. Proceed as follows:

1. Open faucets furthest from tank and allow pump to operate.
2. Air in the system will cause a sputtering flow; allow faucets to run until you have a steady, air free stream.
3. Open and close faucets repeatedly until you are sure all air has been removed.
4. If stream does not become steady, air may be leaking into the system; check for leaks in the piping on the suction side of the pump.

**NOTICE:** To prevent waterlogging, check tank air charge every six months.

## TO CHECK TANK AIR CHARGE

If drawdown (amount of water that comes out of tank per pump cycle) decreases significantly, check as follows:

1. To check air charge in tank, shut off electric power to pump, open faucet near tank, and drain completely.
2. Remove cover and check air pressure at the air valve in top of tank with a standard tire gauge. Air pressure should be 2 PSI below pump pressure switch cut-in setting (that is, if switch closes at 30 PSI, pressure in tank should be at 28 PSI).

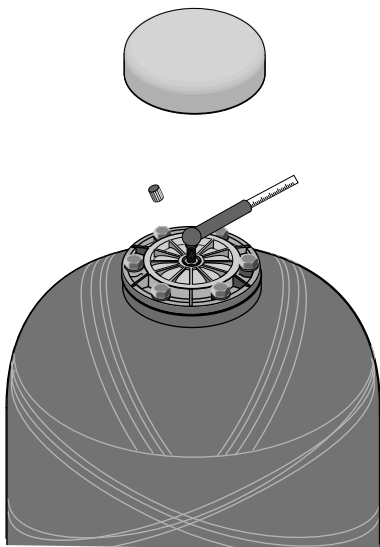

**Figure 6: Use A Tire Gauge To Check Pre-charge In Air Cell**

3. If the air pressure is more than 2 PSI below the cut-in setting, add air to the tank. Use an air compressor or a portable air storage tank.
4. Use soap or liquid detergent to check for air leaks around air valve. Continuous bubbling indicates a leak. If necessary, install new core in air valve. This is the same as those used for automobile tubeless tires.

## TO CHECK PUMP PRESSURE SWITCH SETTING

1. To check pressure switch setting, disconnect power to pump at supply panel (but be sure to leave pressure switch connected to power supply wires).
2. Remove pressure switch cover.
3. Open a faucet near tank.
4. Allow water to drain until pressure switch contacts close; immediately close faucet.
5. Check pressure at valve with standard tire gauge or with pump pressure gauge (if supplied).
6. Pressure gauge should read at pump cut-in setting (30 PSI for 30-50 switch, 20 PSI for 20-40 switch, etc.) If not:
  - A. Adjust switch according to switch manufacturer's instructions.
  - B. Reconnect power supply to pump and pump up pressure in system.
  - C. Disconnect power supply to pump again and re-check switch setting.
  - D. Repeat until pressure switch starts pump within  $\pm 1$  PSI of proper setting.
  - E. If cut-in setting is too low, system will rattle or develop water hammer when pump starts.
  - F. Cut-out setting is not as critical as cut-in setting. Make sure that pump will stop running in a reasonable time. If it does not, cut-out setting may need to be adjusted down slightly. Be sure that after readjustment, system does not rattle or hammer on startup.
7. Re-check tank air pre-charge to be sure it is 2 PSI below pump pressure switch cut-in setting.

## TESTING FOR AIR CELL LEAKAGE

1. **Disconnect power to pump.**
2. Drain all water from tank by opening faucet closest to tank.
3. Remove valve cap from valve and charge air cell.
4. Check air pressure after 24 hours. If air cell leaks, pressure will drop. If so, replace air cell. See instructions on Page 6.

## AIR CELL REPLACEMENT

**CAUTION** To be sure flange cannot blow off of tank, release all air from system before removing capscrews from flange assembly.

1. Disconnect power to pump.
2. Follow steps 1 through 3 under “Testing For Air Cell Leakage”, above.
3. Remove valve core (see Page 7).
4. Remove valve cap, hex nut and washer from valve (see Figure 3, item 3A).
5. Remove capscrews from tank top flange assembly and remove flange (see Figure 3, item 3B).

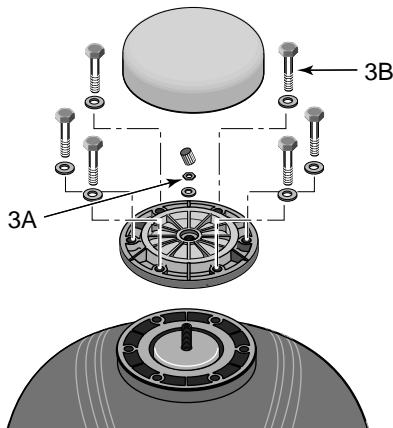

**Figure 3: Remove Weather Cover, Valve Cap and Retaining Nut, and Top Flange Assembly**

6. Air cell may not come out in one piece. Pull air cell up with pliers and cut wherever convenient with single edge razor blade or sharp knife. Continue pulling and cutting until air cell is removed.
7. Before air cell can be inserted into tank, it must be tightly rolled up as follows:
  - A. Remove valve core.
  - B. Place air cell on clean surface with opening to one end; flatten bag to force air out. Pull ends out flat (see Figure 4).

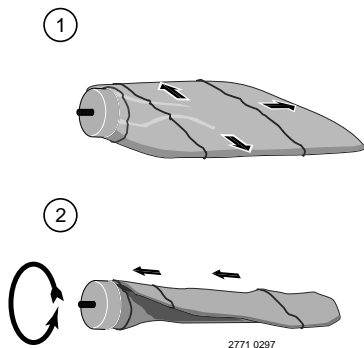

**Figure 4: Spread Air Cell Out Flat and Squeeze Air Out; Roll Cell Tightly, Squeezing Remaining Air Out Through Valve**

- C. To get tightest possible wrap, start on one side and **TIGHTLY** roll air cell to other side (see Figure 4). Force out as much air as possible.
8. Push and turn tightly rolled air cell into tank (see Figure 5).

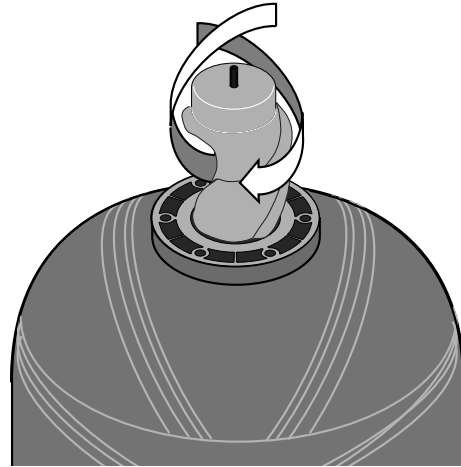

**Figure 5: Turn and Push Air Cell Down Through Top Tank Port. Expel Any Remaining Air From Air Cell As You Go**

9. Shake air cell a few times inside tank to work wrinkles out. It is not necessary to remove all wrinkles from cell.
 

**NOTICE:** Don't push air cell into tank further than its own length. In a large tank, air cell can slip out of reach if pushed too far.
10. Clean tank sealing surface before installing top flange assembly.
11. Clean sealing surface and groove of top cover flange; install O-ring and place cover flange on tank.
12. **NOTICE: Tighten capscrews as follows:**
  - A. Hand tighten all capscrews.
  - B. Tighten one capscrew snug.
  - C. Tighten opposite capscrew snug.
  - D. Proceed, tightening opposite pairs of capscrews (that is, a star pattern) to a snug fit.
  - E. Recheck all capscrews, using same pattern. Be sure all capscrews are tight and that you have a good seal.
 

**NOTICE:** Do not overtighten; you may twist studs off of tank. If you have a torque wrench, tighten to 65 inch-pounds torque.
13. Reinstall valve core in valve.
14. Recharge tank to proper air pressure and install valve cap (see Page 3).
15. Prime pump (see pump owner's manual).

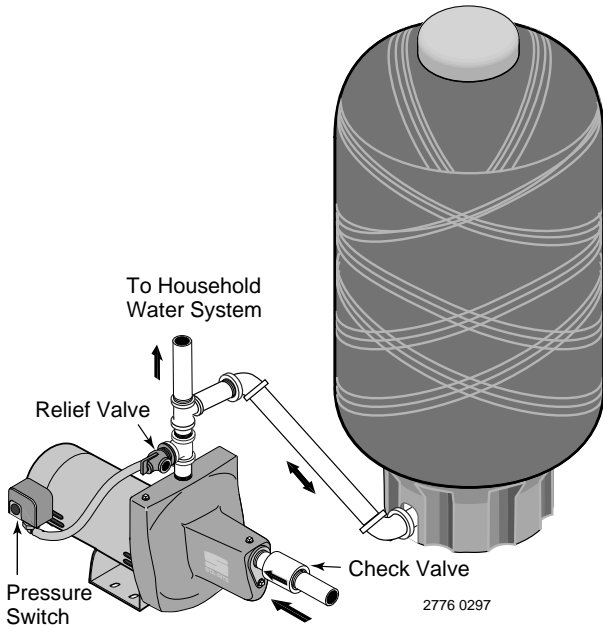

Figure 7: Typical Installation with Jet Pump

**VALVE CORE REPLACEMENT**

**⚠ WARNING** To be sure air valve and core cannot blow out of tank, release all air pressure from tank before removing valve core.

1. Disconnect power to pump.
2. Drain ALL water in system by opening faucet closest to tank.
3. Depress valve core to release ALL air pressure in tank. When air stops coming out of valve, remove core from inside of valve to release remaining pressure. Thread new valve core into tank valve and tighten.

**NOTICE:** Do not overtighten.

4. Recharge tank with air pressure (see Figure 6, page 5) according to Chart I, Page 3; install valve cap; reconnect power to pump. Tank is ready for service.

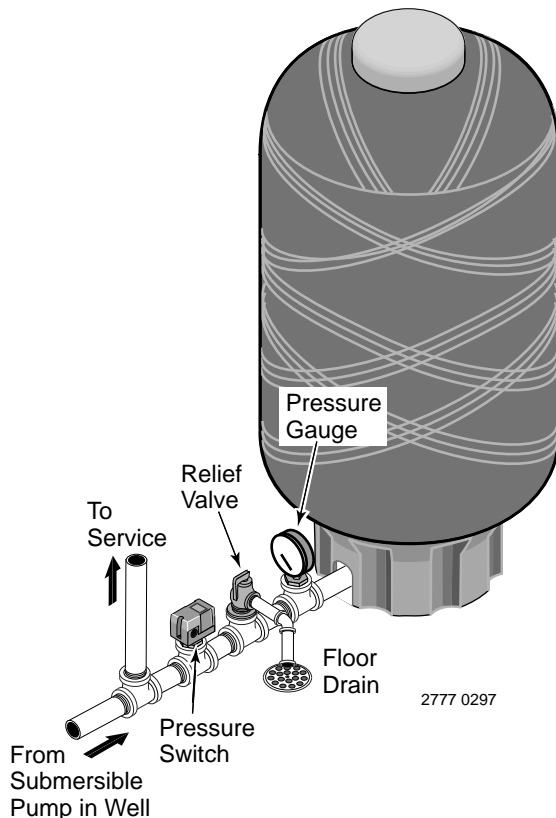

Figure 8: Typical Installation with Submersible Pump

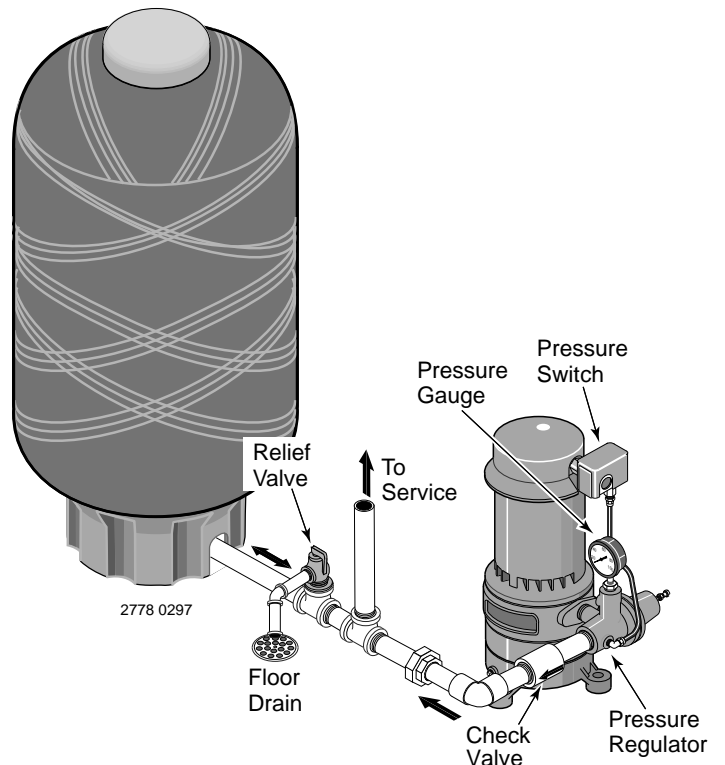
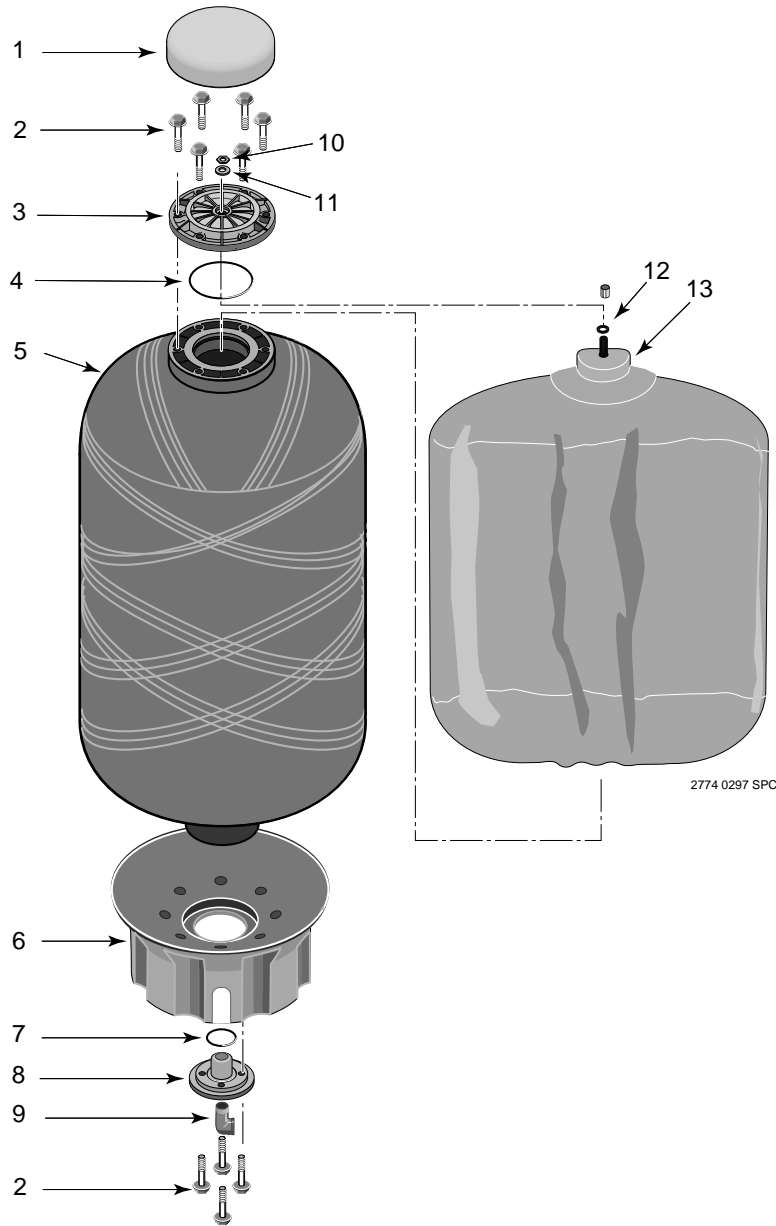

Figure 9: Typical Installation with Vertical Multi-Stage Pump



## REPAIR PARTS LIST

Key No.	Part Description	Qty.	SR20-6S	SR35-10S	SR40-12S	SR48-14S	SR60-18	SR85-25	SR119-35
1	Weather Cover	1	U31-399P	U31-399P	U31-399P	U31-399P	U31-399P	U31-399P	U31-399P
2	Capscrew 3/8-16x1-3/4" Washer Hd.	10	U30-970BT	U30-970BT	U30-970BT	U30-970BT	U30-970BT	U30-970BT	U30-970BT
3	Top Flange	1	U31-362P	U31-362P	U31-362P	U31-362P	U31-362P	U31-362P	U31-362P
4	O-Ring	1	U9-428	U9-428	U9-428	U9-428	U9-428	U9-428	U9-428
5	Tank Assembly	1	U231-385P	U231-386P	1000000541	1000000542	U231-387P	U231-388P	U231-389P
6	Base	1	U31-390P	U31-391P	U31-390P	U31-391P	U31-392P	U31-392P	U31-393P
7	O-Ring	1	U9-414	U9-414	U9-414	U9-414	U9-414	U9-414	U9-414
8	Bottom Flange Assembly (Includes Key No. 9)	1	U131-364P	U131-364P	U131-364P	U131-364P	U131-400P	U131-400P	U131-400P
9	Reducing Elbow, 1-1/4"x1"	1	-	-	-	-	U78-973SS	U78-973SS	U78-973SS
9	Street Elbow, 1" NPT S.S.	1	U78-970SS	U78-970SS	U78-970SS	U78-970SS	-	-	-
10	Nut, Hex	1	U36-201NPD	U36-201NPD	U36-201NPD	U36-201NPD	U36-201NPD	U36-201NPD	U36-201NPD
11	Washer, Flat	1	U43-60SS	U43-60SS	U43-60SS	U43-60SS	U43-60SS	U43-60SS	U43-60SS
12	Square Cut O-Ring	1	U9-416	U9-416	U9-416	U9-416	U9-416	U9-416	U9-416
13	Air Cell	1	U31-394P	U31-395P	1000000537	1000000538	U31-396P	U31-397P	U31-398P

## Signature 2000® Xtended Warranty Submersible/Tank Packages

Size the Signature 2000® Fibrewound or Pro-SourcePlus™ Steel Pressure Tank with a 4" Signature 2000® Series pump per the chart below and receive a **FREE** Xtended 5-Year Warranty on the 4" submersible pump.

### Signature 2000® 4" Submersibles, 2 and 3 Wire

1/2 thru 1-1/2 HP	Fibrewound Pressure Tanks						
	SR20	SR35	SR40	SR48	SR60	SR85	SR119
5 GPM Series	X	X	X				
7 GPM Series	X	X	X				
10 GPM Series		X	X	X			
15 GPM Series				X	X	X	
20 GPM Series					X	X	X
30 GPM Series						X	X
50 GPM Series						(2)	(2)

2 thru 5 HP	Fibrewound Pressure Tanks						
	SR20	SR35	SR40	SR48	SR60	SR85	SR119
5 GPM Series		X	X	X			
7 GPM Series			X	X	X	X	
10 GPM Series					X	X	
15 GPM Series						X	X
20 GPM Series						X	X
30 GPM Series							X
50 GPM Series						(2)	(2)

1/2 thru 1-1/2 HP	Pro-SourcePLUS™ Models						
	PSP42S	PSP42T	PSP75T	PSP82T	PSP120	PSP200	PSP220
5 GPM Series	X	X					
7 GPM Series	X	X					
10 GPM Series			X	X			
15 GPM Series					X	X	
20 GPM Series						X	X
30 GPM Series							X
50 GPM Series							(2)

2 thru 5 HP	Pro-SourcePLUS™ Models						
	PSP42S	PSP42T	PSP75T	PSP82T	PSP120	PSP200	PSP220
5 GPM Series				X			
7 GPM Series					X		
10 GPM Series						X	
15 GPM Series							X
20 GPM Series						(2)	(2)
30 GPM Series					(2)	(2)	(2)
50 GPM Series							(3)

(2) Tanks. (3) Tanks.

FIVE YEAR



**Xtended PROTECTION PLAN**  
**APPLICATION FORM**

## **Signature 2000® 4" Submersible Pumps**

*1/2 HP - 5 HP*

**To the dealer:** Complete the dealer portion of the Xtended Warranty application including the pump model, tank model, date codes and installation date. Present the application form to the homeowner for completion and forward to Signature 2000®.

**To the homeowner:** Complete the homeowner portion of the Xtended Warranty and send the applicable payment along with a copy of your invoice (within 90 days of purchase) to:

Signature 2000®  
Attn: Warranty Administrator  
P.O. Box 95389  
Chicago, IL 60694-5389

Upon receipt of the application form and payment, Signature 2000® will issue an Xtended Warranty Certificate to the homeowner. This certificate must be retained and produced in the event of a failure within the 5 year warranty period. Signature 2000® will also send a copy of the certificate to the installing dealer for notification.

**Xtended Warranty pricing:**

<b>Model</b>	<b>Motor Size</b>	<b>Price</b>
Signature 2000®	1/2 HP - 1-1/2 HP	\$25.00
Signature 2000®	2 HP - 5 HP	\$50.00

**What the warranty covers:** The 5 Year Xtended Warranty provides 4 years of additional warranty coverage, (standard warranty is 1 year) – should the submersible pump models listed above fail within 5 years from the original date of installation. If failure occurs, Signature 2000® agrees to repair or replace at no charge the models identified on this application. This protection plan includes failure caused by abrasion, corrosion and lightning.

**What the warranty does not cover:** The Xtended Warranty Plan does not cover (1) labor charges to pull or reinstall your submersible pump; (2) failure attributed to cables, pipes, controls or accessories; (3) failure attributable to misuse or improper installation; (4) operation without sufficient water (running dry); or (5) consequential, incidental or contingent damage. This Xtended Warranty is not intended to replace insurance coverage which otherwise may be applicable or available.

*This is not an Xtended Warranty – actual **warranty certificate** will come directly from manufacturer after application is received.*

FIVE YEAR



**Signature 2000® 4" Submersible Pumps**

1/2 HP - 5 HP

**Application Form**

(Detach and mail with payment)

Homeowner Name \_\_\_\_\_ Phone # \_\_\_\_\_

Mailing Address \_\_\_\_\_

City, State, Zip \_\_\_\_\_

Pump Address (if different) \_\_\_\_\_

Dealer Name \_\_\_\_\_ Phone # \_\_\_\_\_

Address \_\_\_\_\_

City, State, Zip \_\_\_\_\_

Tank: Model # \_\_\_\_\_ Date code: \_\_\_\_\_

Pump: Model # \_\_\_\_\_ Date code: \_\_\_\_\_

Motor: Model # \_\_\_\_\_ Serial # \_\_\_\_\_

Control Box: Model # \_\_\_\_\_ Date Installed \_\_\_\_\_

Signature (Homeowner): \_\_\_\_\_

